

9C
9D

内螺纹堵头
FEMALE PLUG

代号 PART NO.	螺纹 THREAD	管子外径 TUBE O.D.	尺寸 DIMENSIONS			压力等级 MPa
	F	D	L	L1	S2	
9C-12	M12X1.5	6	18.5	20.5	14	31.5 轻系列 L
9C-14	M14X1.5	8	18	20	17	
9C-16	M16X1.5	10	19.5	21	19	
9C-18	M18X1.5	12	19	20.5	22	
9C-22	M22X1.5	15	19	20.5	27	
9C-26	M26X1.5	18	22	24	32	
9C-30	M30X2	22	22	24	36	16 轻系列 L
9C-36	M36X2	28	23.5	25.5	41	
9C-45	M45X2	35	27	31	50	
9C-52	M52X2	42	27.5	31.5	60	
9D-14	M14X1.5	6	18.5	20.5	17	63 重系列 S
9D-16	M16X1.5	8	18	20	19	
9D-18	M18X1.5	10	19.5	21	22	
9D-20	M20X1.5	12	19	20.5	24	
9D-22	M22X1.5	14	21	23.5	27	
9D-24	M24X1.5	16	22	25	30	40 重系列 S
9D-30	M30X2	20	26.5	30	36	
9D-36	M36X2	25	27.5	32.5	46	
9D-42	M42X2	30	28.5	35	50	
9D-52	M52X2	38	32.5	42	60	

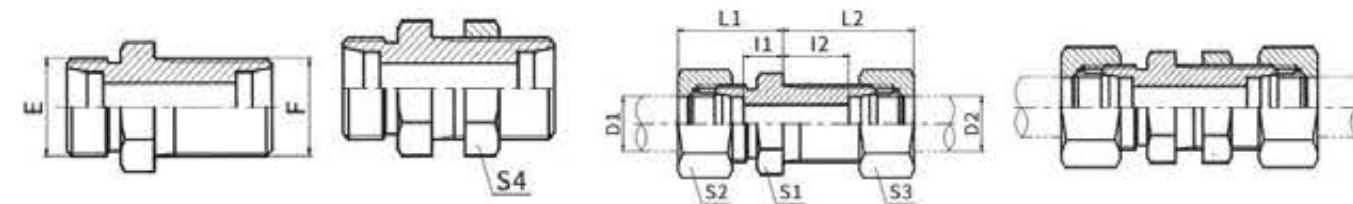

6C
6D

6C-LN
6D-LN

6C-RN
6D-RN

6C-LN/RN
6D-LN/RN

直通过板接头
STRAIGHT BULKHEAD FITTINGS

代号 PART NO.	螺纹 THREAD		管子外径 TUBE O.D.		尺寸 DIMENSIONS							压力等级 MPa
	E	F	D1	D2	I1	I2	L1	L2	S1	S2, S3	S4	
6C-12	M12X1.5	M12X1.5	6	6	7	27	22	42	17	14	17	31.5 轻系列 L
6C-14	M14X1.5	M14X1.5	8	8	8	27	23	42	19	17	19	
6C-16	M16X1.5	M16X1.5	10	10	10	28	25	43	22	19	22	
6C-18	M18X1.5	M18X1.5	12	12	10	29	25	44	24	22	24	
6C-22	M22X1.5	M22X1.5	15	15	12	31	27	46	27	27	30	
6C-26	M26X1.5	M26X1.5	18	18	13.5	32.5	30	49	32	32	36	
6C-30	M30X2	M30X2	22	22	16.5	34.5	33	51	36	36	41	16 轻系列 L
6C-36	M36X2	M36X2	28	28	18.5	35.5	35	52	41	41	46	
6C-45	M45X2	M45X2	35	35	18.5	36.5	40	58	50	50	55	
6C-52	M52X2	M52X2	42	42	19	36	42	59	60	60	65	
6D-14	M14X1.5	M14X1.5	6	6	12	29	27	44	19	17	19	63 重系列 S
6D-16	M16X1.5	M16X1.5	8	8	13	29	28	44	22	19	22	
6D-18	M18X1.5	M18X1.5	10	10	14.5	29.5	31	46	24	22	24	
6D-20	M20X1.5	M20X1.5	12	12	14.5	30.5	31	47	27	24	27	
6D-22	M22X1.5	M22X1.5	14	14	17	32	35	50	30	27	30	
6D-24	M24X1.5	M24X1.5	16	16	16.5	31.5	35	50	32	30	32	40 重系列 S
6D-30	M30X2	M30X2	20	20	17.5	33.5	39	55	41	36	41	
6D-36	M36X2	M36X2	25	25	20	35	44	59	46	46	46	
6D-42	M42X2	M42X2	30	30	21.5	37.5	48	64	50	50	50	
6D-52	M52X2	M52X2	38	38	22	37	53	68	65	60	65	31.5重系列S

注: 如需带锁母订货, 则请在代号后加“LN”, 如6C-30LN; 如需带卡套及卡套螺母订货, 在代号后加“RN”, 如6C-30RN; 如需带锁母、卡套及卡套螺母订货, 在代号后加“LN/RN”, 如6C-30LN/RN.

Note: In case if you are interested to order the adapter with lock nut, please insert suffix "LN" after our part no. for example 6C-30LN, order the adapter with cutting ring and nut, insert suffix "RN" after part no. for example 6C-30RN, order the adapter with lock nut and cutting ring and nut, insert suffix "LN/RN" after part no., for example 6C-30LN/RN.

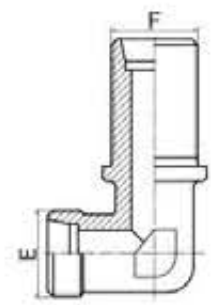
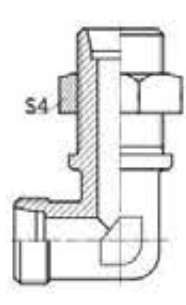
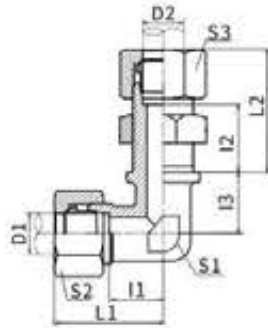
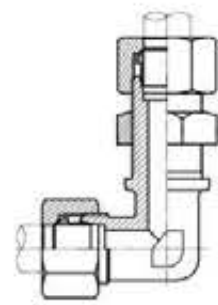
6C9
6D9

6C9-LN
6D9-LN

6C9-RN
6D9-RN

6C9-LN/RN
6D9-LN/RN
90° 弯曲过板接头
90° ELBOW BULKHEAD FITTINGS

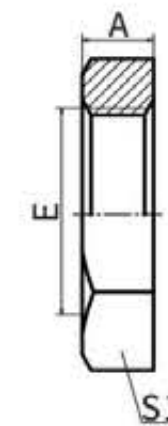
代号 PART NO.	螺纹 THREAD		管子外径 TUBE O.D.		尺寸 DIMENSIONS								压力等级 MPa
	E	F	D1	D2	I1	I2	I3	L1	L2	S1	S2,S3	S4	
6C9-12	M12X1.5	M12X1.5	6	6	27	12	14	42	27	12	14	17	31.5 轻系列 L
6C9-14	M14X1.5	M14X1.5	8	8	27	14	17	42	29	12	17	19	
6C9-16	M16X1.5	M16X1.5	10	10	28	15	18	43	30	14	19	22	
6C9-18	M18X1.5	M18X1.5	12	12	29	17	20	44	32	17	22	24	
6C9-22	M22X1.5	M22X1.5	15	15	31	21	23	46	36	19	27	30	
6C9-26	M26X1.5	M26X1.5	18	18	32.5	23.5	24	49	40	24	32	36	
6C9-30	M30X2	M30X2	22	22	34.5	27.5	30	51	44	27	36	41	16 轻系列 L
6C9-36	M36X2	M36X2	28	28	35.5	30.5	34	52	47	36	41	46	
6C9-45	M45X2	M45X2	35	35	36.5	34.5	39	58	56	41	50	55	
6C9-52	M52X2	M52X2	42	42	36	40	43	59	63	50	60	65	
6D9-14	M14X1.5	M14X1.5	6	6	29	16	17	44	31	12	17	19	63 重系列 S
6D9-16	M16X1.5	M16X1.5	8	8	29	17	18	44	32	14	19	22	
6D9-18	M18X1.5	M18X1.5	10	10	29.5	17.5	20	46	34	17	22	24	
6D9-20	M20X1.5	M20X1.5	12	12	30.5	21.5	21	47	38	17	24	27	
6D9-22	M22X1.5	M22X1.5	14	14	32	22	23	50	40	19	27	30	
6D9-24	M24X1.5	M24X1.5	16	16	31.5	24.5	24	50	43	24	30	32	40 重系列 S
6D9-30	M30X2	M30X2	20	20	33.5	26.5	30	55	48	27	36	41	
6D9-36	M36X2	M36X2	25	25	35	30	34	59	54	36	46	46	
6D9-42	M42X2	M42X2	30	30	37.5	35.5	39	64	62	41	50	50	
6D9-52	M52X2	M52X2	38	38	37	41	43	68	72	50	60	65	31.5重系列S

注:如需带锁母订货,则请在代号后加“LN”,如6C9-30LN;如需带卡套及卡套螺母订货,在代号后加“RN”,如6C9-30RN;如需带锁母、卡套及卡套螺母订货,在代号后加“LN/RN”,如6C9-30LN/RN.

Note:In case if you are interested to order the adapter with lock nut,please insert suffix "LN" after our part no. for example 6C9-30LN,order the adapter with cutting ring and nut,insert suffix "RN" after part no. for example 6C9-30RN,order the adapter with lock nut and cutting ring and nut,insert suffix "LN/RN" after part no.,for example 6C-30LN/RN.

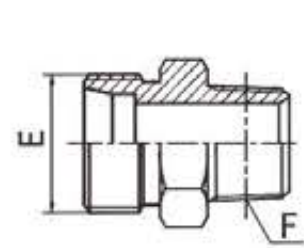
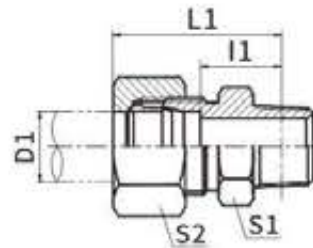

8C
公制螺纹锁母
METRIC LOCK NUT

代号 PART NO.	螺纹 THREAD	尺寸 DIMENSIONS	
	E	A	S1
8C-10	M10×1	6	14
8C-12	M12×1.5	7.5	17
8C-14	M14×1.5	7.5	19
8C-16	M16×1.5	7.5	22
8C-18	M18×1.5	7.5	24
8C-20	M20×1.5	8	27
8C-22	M22×1.5	8	27
8C-24	M24×1.5	8	30
8C-26	M26×1.5	8	32
8C-27D	M27×1.5	10	32
8C-27	M27×2	10	32
8C-30	M30×2	10	36
8C-30D	M30×1.5	10	36
8C-33	M33×2	10	41
8C-36	M36×2	10	41
8C-39	M39×2	10	46
8C-42	M42×2	10	50
8C-45	M45×2	10	55
8C-52	M52×2	10	60
8C-64	M64×2	12.5	75

**1CN
1DN**

**1CN-RN
1DN-RN**
**布锥管外螺纹
NPT MALE**

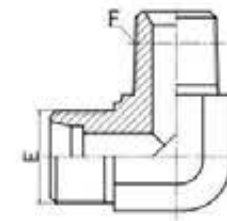
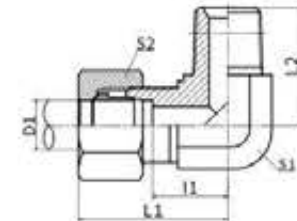
代号 PART NO.	螺纹 THREAD		管子外径 TUBE O.D.	尺寸 DIMENSIONS				压力等级 MPa
	E	F		I1	L1	S1	S2	
1CN-08-02LL	M8X1	Z1/8"X27	4	11.9	23.9	12	10	10
1CN-10-02LL	M10X1	Z1/8"X27	6	12.4	23.9	12	12	特轻系列 LL
1CN-12-02LL	M12X1	Z1/8"X27	8	14.4	25.9	12	14	
1CN-12-02	M12X1.5	Z1/8"X27	6	13.4	28.4	12	14	
1CN-12-04	M12X1.5	Z1/4"X18	6	17.2	32.2	17	14	
1CN-14-04	M14X1.5	Z1/4"X18	8	17.2	32.2	14	17	
1CN-16-06	M16X1.5	Z3/8"X18	10	19.9	53.0	19	19	
1CN-18-04	M18X1.5	Z1/4"X18	12	19.2	34.2	19	22	
1CN-18-06	M18X1.5	Z3/8"X18	12	19.9	34.9	19	22	
1CN-18-08	M18X1.5	Z1/2"X14	12	21.4	36.4	22	22	
1CN-22-08	M22X1.5	Z1/2"X14	15	22.4	37.4	24	27	
1CN-22-20	M22X1.5	Z1.1/4"X11.5	15	29.8	37.4	46	27	
1CN-26-08	M26X1.5	Z1/2"X14	18	22.9	39.4	27	32	
1CN-26-12	M26X1.5	Z3/4"X14	18	22.4	38.9	30	32	
1CN-30-08	M30X2	Z1/2"X14	22	24.4	40.5	32	36	
1CN-30-12	M30X2	Z3/4"X14	22	24.4	40.9	32	36	
1CN-36-16	M36X2	Z1"X11.5	28	29.8	46.3	41	41	
1CN-36-20	M36X2	Z1.1/4"X11.5	28	31.3	46.3	46	41	
1CN-45-20	M45X2	Z1.1/4"X11.5	35	30.3	51.8	46	50	
1CN-52-20	M52X2	Z1.1/4"X11.5	42	31.8	55.8	55	60	
1CN-52-24	M52X2	Z1.1/2"X11.5	42	32.8	55.8	55	60	
1DN-14-04	M14X1.5	Z1/4"X18	6	22.2	37.2	17	17	
1DN-16-04	M16X1.5	Z1/4"X18	8	22.2	37.2	17	19	
1DN-18-04	M18X1.5	Z1/4"X18	10	21.7	38.2	19	22	
1DN-18-06	M18X1.5	Z3/8"X18	10	22.4	38.9	19	22	
1DN-20-04	M20X1.5	Z1/4"X18	12	23.7	40.2	22	24	
1DN-20-06	M20X1.5	Z3/8"X18	12	24.4	40.9	22	24	
1DN-20-08	M20X1.5	Z1/2"X14	12	25.9	42.4	22	24	
1DN-22-08	M22X1.5	Z1/2"X14	14	27.4	45.4	24	27	
1DN-24-08	M24X1.5	Z1/2"X14	16	26.9	45.4	27	30	
1DN-30-12	M30X2	Z3/4"X14	20	28.4	49.9	32	36	
1DN-36-12	M36X2	Z3/4"X14	25	30.9	56.8	41	46	
1DN-36-16	M36X2	Z1"X11.5	25	35.3	59.3	41	46	
1DN-42-16	M42X2	Z1"X11.5	25	35.8	59.3	46	46	
1DN-42-20	M42X2	Z1.1/4"X11.5	30	36.3	62.8	46	50	
1DN-52-24	M52X2	Z1.1/2"X11.5	38	39.8	70.8	55	60	

注：如需带卡套及卡套螺母整套订货，则请在代号后加“RN”，如1DN-30-12RN。
 Note: In case if you are interested to order the adapter in complete set with cutting ring and nut, it is necessary to insert suffix "RN" after our part no., for example 1DN-30-12RN.

**1CN9
1DN9**

**1CN9-RN
1DN9-RN**
**90° 弯布锥管外螺纹
90° ELBOW NPT MALE**

代号 PART NO.	螺纹 THREAD		管子外径 TUBE O.D.	尺寸 DIMENSIONS					压力等级 MPa
	E	F		I1	L1	L2	S1	S2	
1CN-08-02LL	M8X1	Z1/8"X27	4	11	21	17	10	10	10
1CN-10-02LL	M10X1	Z1/8"X27	6	9.5	21	17	10	12	特轻系列 LL
1CN-12-02LL	M12X1	Z1/8"X27	8	11.5	23	20	12	14	
1CN9-12-02	M12X1.5	Z1/8"X27	6	13	28	21	11	14	
1CN9-12-04	M12X1.5	Z1/4"X18	6	15.5	30.5	25.5	14	14	
1CN9-14-04	M14X1.5	Z1/4"X18	8	15.5	30.5	25.5	14	17	
1CN9-16-06	M16X1.5	Z3/8"X18	10	17.5	32.5	29.5	16	19	
1CN9-18-04	M18X1.5	Z1/4"X18	12	19	34	28	19	22	
1CN9-18-06	M18X1.5	Z3/8"X18	12	19	34	31	19	22	
1CN9-18-08	M18X1.5	Z1/2"X14	12	21	36	36.7	22	22	
1CN9-22-06	M22X1.5	Z3/8"X18	15	22	37	32.5	22	27	
1CN9-22-08	M22X1.5	Z1/2"X14	15	22	37	36.7	22	27	
1CN9-26-08	M26X1.5	Z1/2"X14	18	25.5	42	40	27	32	
1CN9-26-12	M26X1.5	Z3/4"X14	18	25.5	42	44	27	32	
1CN9-30-12	M30X2	Z3/4"X14	22	29.3	45.8	45	30	36	
1CN9-30-16	M30X2	Z1"X11.5	22	32	50	33	36		25 轻系列 L
1CN9-36-16	M36X2	Z1"X11.5	28	33.3	49.8	51.5	36	41	
1CN9-45-20	M45X2	Z1.1/4"X11.5	35	39.2	60.7	63	48	50	
1CN9-52-24	M52X2	Z1.1/2"X11.5	42	44.8	67.8	65	55	60	
1DN9-14-04	M14X1.5	Z1/4"X18	6	17.5	32.5	25.5	14	17	
1DN9-16-04	M16X1.5	Z1/4"X18	8	18.5	33.7	26.5	16	19	
1DN9-18-06	M18X1.5	Z3/8"X18	10	19.5	36	31	19	22	
1DN9-20-04	M20X1.5	Z1/4"X18	12	19.5	36	28	19	24	
1DN9-20-06	M20X1.5	Z3/8"X18	12	19.5	36	31	19	24	
1DN9-22-06	M22X1.5	Z3/8"X18	14	23	41	32.5	22	27	
1DN9-22-08	M22X1.5	Z1/2"X14	14	23	41	36.7	22	27	
1DN9-24-06	M24X1.5	Z3/8"X18	16	24	42.5	33.5	24	30	
1DN9-24-08	M24X1.5	Z1/2"X14	16	24	42.5	37.5	24	30	
1DN9-30-08	M30X2	Z1/2"X14	20	28	49.8	41	30	36	
1DN9-30-12	M30X2	Z3/4"X14	20	28	49.8	45	30	36	
1DN9-36-12	M36X2	Z3/4"X14	25	32.8	56.8	49	36	46	
1DN9-36-16	M36X2	Z1"X11.5	25	32.8	56.8	51.5	36	46	
1DN9-42-16	M42X2	Z1"X11.5	30	36.2	62.7	54.5	41	50	
1DN9-42-20	M42X2	Z1.1/4"X11.5	30	36.2	62.7	54.5	41	50	
1DN9-52-20	M52X2	Z1.1/4"X11.5	38	45.8	76.8	65	55	60	
1DN9-52-24	M52X2	Z1.1/2"X11.5	38	45.8	76.8	65	55	60	

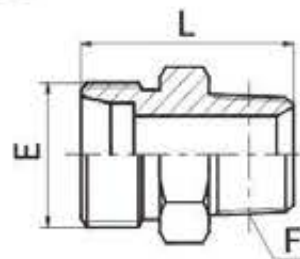
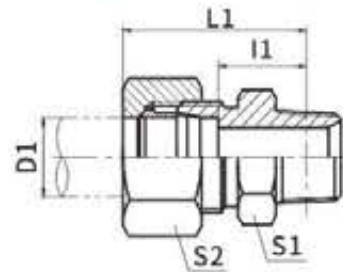
注：如需带卡套及卡套螺母整套订货，则请在代号后加“RN”，如1CN9-30-12RN。
 Note: In case if you are interested to order the adapter in complete set with cutting ring and nut, it is necessary to insert suffix "RN" after our part no., for example 1CN9-30-12RN.

1CT-SP
1DT-SP

1CT-SP/RN
1DT-SP/RN
英锥管外螺纹
BSPT MALE

代号 PART NO.	螺纹 THREAD		管子外径 TUBE O.D. D	尺寸 DIMENSIONS				压力等级 MPa
	E	F		I1	L1	S1	S2	
1CT-08-02LL	M8x1	R1/8"x28	4	12	22	10	10	10 特轻系列 LL
1CT-10-02LL	M10x1	R1/8"x28	6	10.5	22	12	12	
1CT-12-02LL	M12x1	R1/8"x28	8	12.5	24	12	14	
1CT-12-04LL	M12x1	R1/4"x19	8	16.5	28	14	14	
1CT-12-02SP	M12x1.5	R1/8"x28	6	13	28	12	14	25 轻系列
1CT-12-04SP	M12x1.5	R1/4"x19	6	16.5	31.5	14	14	
1CT-14-04SP	M14x1.5	R1/4"x19	8	16.5	31.5	14	17	
1CT-16-04SP	M16x1.5	R1/4"x19	10	17.5	32.5	17	19	
1CT-16-06SP	M16x1.5	R3/8"x19	10	18.6	33.6	19	19	
1CT-16-08SP	M16x1.5	R1/2"x14	10	21.8	36.8	22	19	
1CT-18-04SP	M18x1.5	R1/4"x19	12	18.5	33.5	19	22	
1CT-18-06SP	M18x1.5	R3/8"x19	12	18.6	33.6	19	22	
1CT-18-08SP	M18x1.5	R1/2"x14	12	21.8	36.8	22	22	
1CT-22-08SP	M22x1.5	R1/2"x14	15	22.8	37.8	24	27	
1CT-26-08SP	M26x1.5	R1/2"x14	18	23.3	39.8	27	32	16 轻系列
1CT-26-12SP	M26x1.5	R3/4"x14	18	22	38.5	30	32	
1CT-30-12SP	M30x2	R3/4"x14	22	24	40.5	32	36	
1CT-36-16SP	M36x2	R1"x11	28	29.6	46.1	38	41	
1CT-36-20SP	M36x2	R1.1/4"x11	28	29.3	45.8	46	41	
1CT-45-20SP	M45x2	R1.1/4"x11	35	28.3	49.8	46	50	
1CT-52-20SP	M52x2	R1.1/4"x11	42	29.8	52.8	55	60	
1CT-52-24SP	M52x2	R1.1/2"x11	42	29.8	52.8	55	60	
1DT-14-04SP	M14x1.5	R1/4"x19	6	13	36.5	17	17	40 重系列 S
1DT-16-04SP	M16x1.5	R1/4"x19	8	21.5	36.5	17	19	
1DT-18-04SP	M18x1.5	R1/4"x19	10	21	37.5	19	22	
1DT-20-04SP	M20x1.5	R1/4"x19	12	23	39.5	22	24	
1DT-20-06SP	M20x1.5	R3/8"x19	12	23.1	39.6	22	24	
1DT-22-06SP	M22x1.5	R3/8"x19	14	24.6	42.6	24	27	
1DT-22-08SP	M22x1.5	R1/2"x14	14	27.8	45.8	24	27	
1DT-24-06SP	M24x1.5	R3/8"x19	16	24.1	42.6	27	30	
1DT-24-08SP	M24x1.5	R1/2"x14	16	27.3	45.8	27	30	
1DT-30-12SP	M30x2	R3/4"x14	20	28	49.5	32	36	25 重系列 S
1DT-36-12SP	M36x2	R3/4"x14	25	29.5	53.5	38	46	
1DT-36-16SP	M36x2	R1"x11	25	34.1	58.1	38	46	
1DT-42-16SP	M42x2	R1"x11	30	35.6	62.1	46	50	
1DT-42-20SP	M42x2	R1.1/4"x11	30	34.3	60.8	46	50	
1DT-52-20SP	M52x2	R1.1/4"x11	38	36.8	67.8	55	60	
1DT-52-24SP	M52x2	R1.1/2"x11	38	36.8	67.8	55	60	

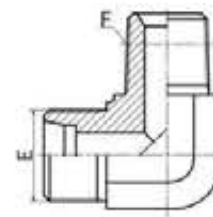
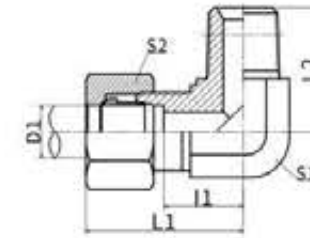
注：如需带卡套及卡套螺母整套订货，则请在代号后加“RN”，如1DT-22-08SP/RN。
 Note: In case if you are interested to order the adapter in complete set with cutting ring and nut, it is necessary to insert suffix "RN" after our part no., for example 1DT-22-08SP/RN.

1CT9-SP
1DT9-SP

1CT9-SP/RN
1DT9-SP/RN
90° 弯英锥管外螺纹
90° ELBOW BSPT MALE

代号 PART NO.	螺纹 THREAD		管子外径 TUBE O.D.	尺寸 DIMENSIONS					压力等级 MPa
	E	F		I1	L1	L2	S1	S2	
1CT9-08-02LL	M8X1	R1/8"X28	4	11	21	17	10	10	10 特轻系列 LL
1CT9-10-02LL	M10X1	R1/8"X28	6	9.5	21	17	10	12	
1CT9-12-02LL	M12X1	R1/8"X28	8	11.5	23	20	12	14	
1CT9-12-02SP	M12X1.5	R1/8"X28	6	13	28	21	11	14	
1CT9-12-04SP	M12X1.5	R1/4"X19	6	15.5	30.5	25.5	14	14	
1CT9-14-04SP	M14X1.5	R1/4"X19	8	15.5	30.5	25.5	14	17	
1CT9-16-04SP	M16X1.5	R1/4"X19	10	17.5	32.5	26.5	16	19	
1CT9-16-06SP	M16X1.5	R3/8"X19	10	17.5	32.5	28.5	16	19	
1CT9-16-08SP	M16X1.5	R1/2"X14	10	21	36	36	22	19	
1CT9-18-04SP	M18X1.5	R1/4"X19	12	21	34	28	19	22	
1CT9-18-06SP	M18X1.5	R3/8"X19	12	19	34	30.5	19	22	
1CT9-18-08SP	M18X1.5	R1/2"X14	12	21	36	36	22	22	
1CT9-22-06SP	M22X1.5	R3/8"X19	15	22	37	32.5	22	27	
1CT9-22-08SP	M22X1.5	R1/2"X14	15	22	37	36	22	27	
1CT9-22-12SP	M22X1.5	R3/4"X14	15	25.5	40.5	43.5	27	27	
1CT9-26-08SP	M26X1.5	R1/2"X14	18	25.5	42	39.5	27	32	16 轻系列 L
1CT9-26-12SP	M26X1.5	R3/4"X14	18	25.5	42	43.5	27	32	
1CT9-30-12SP	M30X2	R3/4"X14	22	29.5	45.8	45.3	30	36	
1CT9-30-16SP	M30X2	R1"X11	22	31.5	48	50	33	36	
1CT9-36-16SP	M36X2	R1"X11	28	33.3	49.8	52	36	41	
1CT9-36-20SP	M36X2	R1.1/4"X11	28	36.2	52.7	57	41	41	
1CT9-45-20SP	M45X2	R1.1/4"X11	35	39.2	60.7	61	48	50	
1CT9-52-24SP	M52X2	R1.1/2"X11	42	44.8	67.8	68	55	60	
1DT9-14-04SP	M14X1.5	R1/4"X19	6	17.5	32.5	25.5	14	17	40 重系列 S
1DT9-16-04SP	M16X1.5	R1/4"X19	8	18.7	33.7	26.5	16	19	
1DT9-18-06SP	M18X1.5	R3/8"X19	10	19.5	36	30.5	19	22	
1DT9-20-04SP	M20X1.5	R1/4"X19	12	19.5	36	28	19	24	
1DT9-20-06SP	M20X1.5	R3/8"X19	12	19.5	36	30.5	19	24	
1DT9-22-06SP	M22X1.5	R3/8"X19	14	23	41	32.5	22	27	
1DT9-22-08SP	M22X1.5	R1/2"X14	14	23	41	36	22	27	
1DT9-24-06SP	M24X1.5	R3/8"X19	16	24	42.5	33.5	24	30	
1DT9-24-08SP	M24X1.5	R1/2"X14	16	24	42.5	37.3	24	30	
1DT9-30-08SP	M30X2	R1/2"X14	20	28.3	49.8	41	30	36	25 重系列 S
1DT9-30-12SP	M30X2	R3/4"X14	20	28.3	49.8	45.3	30	36	
1DT9-36-12SP	M36X2	R3/4"X14	25	33.3	57.3	52	36	46	
1DT9-36-16SP	M36X2	R1"X11	25	32.8	56.8	52.5	36	46	
1DT9-42-16SP	M42X2	R1"X11	30	36.2	62.7	56.5	41	50	
1DT9-42-20SP	M42X2	R1.1/4"X11	30	36.2	62.7	57	41	50	
1DT9-52-20SP	M52X2	R1.1/4"X11	38	45.8	76.8	67	55	60	
1DT9-52-24SP	M52X2	R1.1/2"X11	38	45.8	76.8	68	55	60	

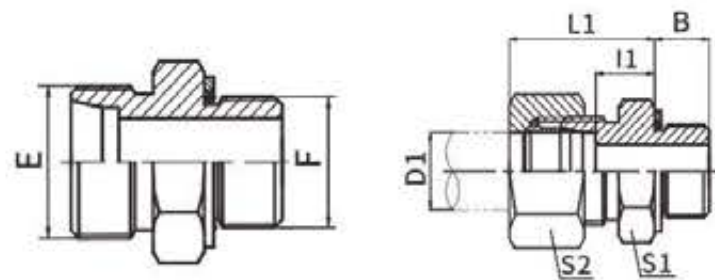
注：如需带卡套及卡套螺母整套订货，则请在代号后加“RN”，如1CT9-30-12SP/RN。
 Note: In case if you are interested to order the adapter in complete set with cutting ring and nut, it is necessary to insert suffix "RN" after our part no., for example 1CT9-30-12SP/RN.

**1CH
1DH**
**1CH-RN
1DH-RN**
**公制外螺纹柱端ISO 6149
METRIC MALE THREAD STUD
ENDS ISO 6149**

代号 PART NO.	螺纹 THREAD		管子外径D1 TUBE O.D.	O 形 圈 O RING	尺寸 DIMENSIONS					压力等级 MPa	
	E	F			B	I1	L1	S1	S2		
1CH-12-10	M12X1.5	M10X1	6	O08.1X1.6	8.5	9.5	23	14	14	31.5 轻系列 L	
1CH-14	M14X1.5	M14X1.5	8	O11.3X2.4	11	10	25	19	17		
1CH-16-14	M16X1.5	M14X1.5	10	O11.3X2.4	11	13	26	19	19		
1CH-16	M16X1.5	M16X1.5	10	O13.3X2.4	11.5	13	28	22	19		
1CH-18-16	M18X1.5	M16X1.5	12	O13.3X2.4	11.5	12	27	22	22		
1CH-22-18	M22X1.5	M18X1.5	15	O15.3X2.4	12.5	13.5	29	24	27		
1CH-22-20	M22x1.5	M20X1.5	15	O17.3X2.4	12	15	30.5	27	27		
1CH-22	M22X1.5	M22X1.5	15	O19.3X2.4	13	15	31	27	27		
1CH-26-22	M26X1.5	M22X1.5	18	O19.3X2.4	13	14.5	31	27	32		
1CH-26	M26X1.5	M26X1.5	18	O23.5X3.0	13.5	13.5	31	32	32		
1CH-30-27	M30X2	M27X2	22	O23.5X3.0	16	16.5	33	32	36		16 轻系列 L
1CH-30	M30X2	M30X2	22	O26.5X3.0	16	17.5	33	36	36		
1CH-36-27	M36X2	M27X2	28	O23.5X3.0	16	17.5	34	41	41		
1CH-36-33	M36X2	M33X2	28	O29.5X3.0	16	17.5	34	41	41		
1CH-45-42	M45X2	M42X2	35	O38.5X3.0	16	17.5	37	50	50		
1CH-52-48	M52X2	M48X2	42	O44.5X3.0	17.5	19		55	60		
1DH-14	M14X1.5	M14X1.5	6	O11.3X2.4	11	15	28	19	17	63 重系列 S	
1DH-14-12	M14X1.5	M12X1.5	6	O09.3X2.4	11	13	28	17	17		
1DH-16-14	M16X1.5	M14X1.5	8	O11.3x2.4	11	15	30	19	19		
1DH-18-16	M18X1.5	M16X1.5	10	O13.3x2.4	11.5	15	31	22	22		
1DH-20-18	M20X1.5	M18X1.5	12	O15.3X2.4	12.5	17	33	24	24	40 重系列 S	
1DH-24-22	M24X1.5	M22X1.5	16	O19.3x2.4	13	18.5	37	27	30		
1DH-30	M30X2	M30X2	20	O26.5X3.0	16	20.5	42	36	36		
1DH-30-27	M30X2	M27X2	20	O23.5X3.0	16	20.5	42	32	36		
1DH-36-27	M36X2	M27X2	25	O23.5X3.0	16	23	47	41	46		
1DH-36-33	M36X2	M33X2	25	O29.5X3.0	16	23	47	41	46		
1DH-42	M42x2	M42X2	30	O38.5X3.0	16	23.5	50	50	50		

注：如需带卡套及卡套螺母整套订货，则请在代号后加“RN”，如1DH-20-18RN。
 Note: In case if you are interested to order the adapter in complete set with cutting ring and nut, it is necessary to insert suffix "RN" after our part no., for example 1DH-20-18RN.

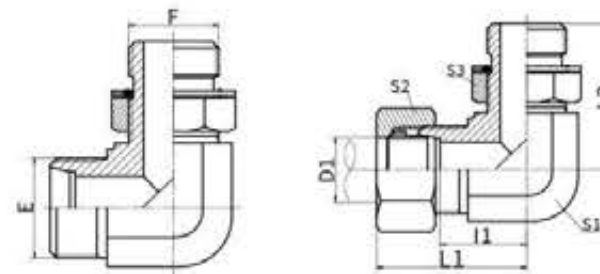

**1CH9-OG
1DH9-OG**
**1CH9-OG/RN
1DH9-OG/RN**
**90° 弯公制外螺纹可调向柱端ISO 6149
90° ELBOW METRIC MALE THREAD
ADJUSTABLE STUD ENDS ISO 6149**

代号 PART NO.	螺纹 THREAD		管子外径D1 TUBE O.D.	O 形 圈 O RING	尺寸 DIMENSIONS						压力等级 MPa	
	E	F			I1	L1	L2	S1	S2	S3		
1CH9-12-10OG	M12X1.5	M10X1	6	O08.1X1.6	13	28	26.5	11	14	14	31.5 轻系列 L	
1CH9-14-12OG	M14X1.5	M12X1.5	8	O09.3X2.4	15.5	30.5	32	14	17	17		
1CH9-16-14OG	M16X1.5	M14X1.5	10	O11.3X2.4	17.5	32.5	34	17	19	19		
1CH9-18-16OG	M18X1.5	M16X1.5	12	O13.3X2.4	19	34	36	19	22	22		
1CH9-22-18OG	M22X1.5	M18X1.5	15	O15.3X2.4	22	37	39.5	22	27	24		
1CH9-26-22OG	M26X1.5	M22X1.5	18	O19.3X2.4	25.5	42	43.5	27	32	27		
1CH9-30-27OG	M30X2	M27X2	22	O23.5X3.0	29.3	45.8	50	30	36	32	16 轻系列L	
1CH9-36-33OG	M36X2	M33X2	28	O29.5X3.0	33.3	49.8	54	36	41	41		
1CH9-45-42OG	M45X2	M42X2	35	O38.5X3.0	39	60.5	61	41	50	50		
1CH9-52-48OG	M52X2	M48X2	42	O44.5X3.0	40	63	64.5	50	60	55		
1DH9-14-12OG	M14X1.5	M12X1.5	6	O09.3X2.4	17.5	32.5	32	14	17	17		63 重系列 S
1DH9-16-14OG	M16X1.5	M14X1.5	8	O11.3X2.4	18.7	33.7	34	16	19	19		
1DH9-18-16OG	M18X1.5	M16X1.5	10	O13.3X2.4	19.5	36	36	19	22	22		
1DH9-20-18OG	M20X1.5	M18X1.5	12	O15.3X2.4	19.5	36	37	19	24	24		
1DH9-22-20OG	M22X1.5	M20X1.5	14	O17.3X2.4	23	41	40	22	27	27		
1DH9-24-22OG	M24X1.5	M22X1.5	16	O19.3X2.4	24	42	37.5	24	30	27		
1DH9-30-27OG	M30X2	M27X2	20	O23.5X3.0	28.3	49.8	50	30	36	32	40 重系列 S	
1DH9-36-33OG	M36X2	M33X2	25	O29.5X3.0	32.8	56.8	54	36	46	41		
1DH9-42OG	M42X2	M42X2	30	O38.5X3.0	36.2	62.7	57.2	41	50	50		
1DH9-52-48OG	M52X2	M48X2	38	O44.5X3.0	41	72	64.5	50	60	55		

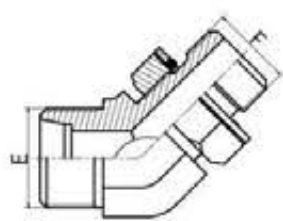
注：如需带卡套及卡套螺母整套订货，则请在代号后加“RN”，如1DH9-20-18OG/RN。
 Note: In case if you are interested to order the adapter in complete set with cutting ring and nut, it is necessary to insert suffix "RN" after our part no., for example 1DH9-20-18OGRN.

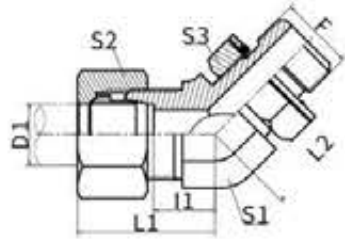

1CH4-OG
1DH4-OG



1CH4-OG/RN
1DH4-OG/RN

45° 公制外螺纹可调向柱端ISO 6149
45° ELBOW METRIC MALE ADJUSTABLE
STUD END ISO 6149

代号 PART NO.	螺纹 THREAD		管子外径D1 TUBE O.D.	O 形 圈 O RING	尺寸 DIMENSIONS						压力等级 MPa
	E	F			I1	L1	L2	S1	S2	S3	
1CH4-12-10OG	M12×1.5	M10×1	6	O08.1×1.6	10	25	25.5	11	14	14	31.5 轻系列 L
1CH4-14-12OG	M14×1.5	M12×1.5	8	O09.3×2.4	11	26	30	14	17	17	
1CH4-16-14OG	M16×1.5	M14×1.5	10	O11.3×2.4	12.3	27.3	30.5	16	19	19	
1CH4-18-16OG	M18×1.5	M16×1.5	12	O13.3×2.4	13	28	34	19	22	22	
1CH4-22-18OG	M22×1.5	M18×1.5	15	O15.3×2.4	15	30	38	22	27	24	
1CH4-26-22OG	M26×1.5	M22×1.5	18	O19.3×2.4	16.5	33	40.5	27	32	27	
1CH4-30-27OG	M30×2	M27×2	22	O23.5×3.0	19.7	36.2	48	30	36	32	16 轻系列 L
1CH4-36-33OG	M36×2	M33×2	28	O29.5×3.0	21.5	38	49.5	36	41	41	
1CH4-45-42OG	M45×2	M42×2	35	O38.5×3.0	25.5	47	55	48	50	50	
1DH4-14-12OG	M14×1.5	M12×1.5	6	O09.3×2.4	13	28	30	14	17	17	40 重系列 S
1DH4-16-14OG	M16×1.5	M14×1.5	8	O11.3×2.4	13.5	28.3	30.5	16	19	19	
1DH4-18-16OG	M18×1.5	M16×1.5	10	O13.3×2.4	13.5	30	34	19	22	22	
1DH4-20-18OG	M20×1.5	M18×1.5	12	O15.3×2.4	13.5	30	37	19	24	24	
1DH4-24-22OG	M24×1.5	M22×1.5	16	O19.3×2.4	16.2	34.7	40	24	30	27	
1DH4-30-27OG	M30×2	M27×2	20	O23.5×3.0	18.7	40.2	48	30	36	32	
1DH4-36-33OG	M36×2	M33×2	25	O29.5×3.0	21	45	49.5	36	46	41	31.5重系列S
1DH4-42-42OG	M42×2	M42×2	30	O38.5×3.0	24.3	50.8	54	41	50	50	25重系列S

注：如需带卡套及卡套螺母整套订货，则请在代号后加“RN”，如1CH4-30-27OG/RN。
Note: In case if you are interested to order the adapter in complete set with cutting ring and nut, it is necessary to insert suffix "RN" after our part no., for example 1CH4-30-27OG/RN.

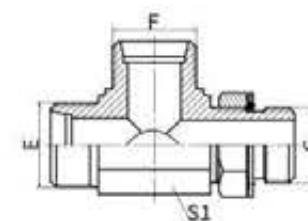

ACCH-OG
ADDH-OG

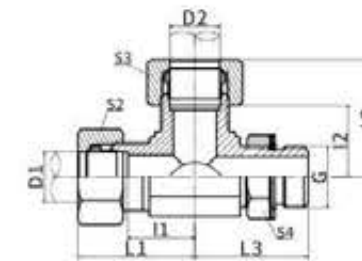

ACCH-OG/RN
ADDH-OG/RN

公制螺纹可调向柱端ISO6149主支三通
METRIC MALE ADJUSTABLE
STUD END ISO 6149 RUN TEE

代号 PART NO.	螺纹 THREAD		管子外径TUBE O.D.		O 形 圈 O RING	尺寸 DIMENSIONS					压力等级 MPa
	E, F	G	D1	D2		A	B	C	S1	S2	
ACCH-12-12-10OG	M12X1.5	M10X1	6	6	8.1X1.6	20	20	26.5	11	14	31.5 轻系列 L
ACCH-14-14-12OG	M14X1.5	M12X1.5	8	8	9.3X2.4	22.5	22.5	32.5	14	17	
ACCH-16-16-14OG	M16X1.5	M14X1.5	10	10	11.3X2.4	24.5	24.5	34	16	19	
ACCH-18-18-16OG	M18X1.5	M16X1.5	12	12	13.3X2.4	26	26	36	19	22	
ACCH-26-26-22OG	M26X1.5	M22X1.5	18	18	19.3X2.4	33	33	43.5	27	27	
ACCH-30-30-27OG	M30X2	M27X2	22	22	23.5X3	37	37	50	30	32	
ACCH-36-36-33OG	M36X2	M33X2	28	28	29.2X3	40.7	40.7	54	36	41	16 轻系列L
ADDH-14-14-12OG	M14X1.5	M12X1.5	6	6	9.3X2.4	25.8	25.8	32	14	17	63 重系列 S
ADDH-16-16-14OG	M16X1.5	M14X1.5	8	8	11.3X2.4	27	27	34	16	19	
ADDH-18-18-16OG	M18X1.5	M16X1.5	10	10	13.3X2.4	28.5	28.5	36	19	22	
ADDH-20-20-18OG	M20X1.5	M18X1.5	12	12	15.3X2.4	28.5	28.5	37	19	24	
ADDH-24-24-22OG	M24X1.5	M22X1.5	16	16	19.3X2.4	32.2	32.2	41.2	24	27	
ADDH-30-30-27OG	M30X2	M27X2	20	20	23.5X3	41.5	41.5	50	30	32	
ADDH-36-36-33OG	M36X2	M33X2	25	25	29.2X3	46.5	46.5	54	36	41	40 重系列 S
ADDH-42-42-42OG	M42X2	M42X2	30	30	38.5X3	49.5	49.5	57.2	41	50	S

注：如需带卡套及卡套螺母整套订货，则请在代号后加“RN”，如ACCH-30-30-27OG/RN。
Note: In case if you are interested to order the adapter in complete set with cutting ring and nut, it is necessary to insert suffix "RN" after our part no., for example ACCH-30-30-27OG/RN.

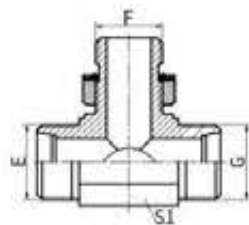

ACHC-OG
ADHD-OG

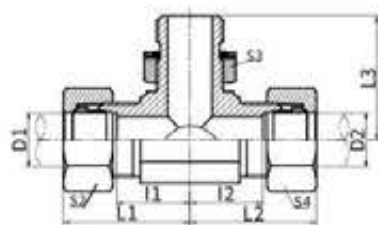

ACHC-OG/RN
ADHD-OG/RN

公制外螺纹可调向柱端
ISO 6149分支三通
METRIC MALE ADJUSTABLE STUD
END ISO 6149 BRANCH TEE

代号 PART NO.	螺纹 THREAD		管子外径D1,D2 TUBE O.D.	O 形圈 O RING	尺寸 DIMENSIONS						压力等级 MPa
	E,G	F			I1,I2	L1,L2	L3	S1	S2,S4	S3	
ACHC-12-10-12OG	M12×1.5	M10×1	6	O08.1×1.6	13	28	26.5	11	14	14	31.5 轻系列 L
ACHC-14-12-14OG	M14×1.5	M12×1.5	8	O09.3×2.4	15.5	30.5	32	14	17	17	
ACHC-16-14-16OG	M16×1.5	M14×1.5	10	O11.3×2.4	17.5	32.5	34	16	19	19	
ACHC-18-16-18OG	M18×1.5	M16×1.5	12	O13.3×2.4	19	34	36	19	22	22	
ACHC-22-18-22OG	M22×1.5	M18×1.5	15	O15.3×2.4	22	37	39.5	22	27	24	
ACHC-26-22-26OG	M26×1.5	M22×1.5	18	O19.3×2.4	25.5	42	43.5	27	32	27	
ACHC-30-27-30OG	M30×2	M27×2	22	O23.5×3.0	29.3	45.8	50	30	36	32	16 轻系列L
ACHC-36-33-36OG	M36×2	M33×2	28	O29.5×3.0	33.3	49.8	54	36	41	41	
ADHD-14-12-14OG	M14×1.5	M12×1.5	6	O09.3×2.4	17.5	32.5	32	14	17	17	63 重系列 S
ADHD-16-14-16OG	M16×1.5	M14×1.5	8	O11.3×2.4	18.7	33.7	34	16	19	19	
ADHD-18-16-18OG	M18×1.5	M16×1.5	10	O13.3×2.4	19.5	36	36	19	22	22	
ADHD-20-18-20OG	M20×1.5	M18×1.5	12	O15.3×2.4	19.5	36	37	19	24	24	
ADHD-24-22-24OG	M24×1.5	M22×1.5	16	O19.3×2.4	24	42	37.5	24	30	27	
ADHD-30-27-30OG	M30×2	M27×2	20	O23.5×3.0	28.3	49.8	50	30	36	32	40 重系列 S
ADHD-36-33-36OG	M36×2	M33×2	25	O29.5×3.0	32.8	56.8	54	36	46	41	
ADHD-42-42-42OG	M42×2	M42×2	30	O38.5×3.0	36.2	62.7	57.2	41	50	50	

注：如需带卡套及卡套螺母整套订货，请在代号后加“RN”，如ACHC-30-27-30OG/RN。
Note: In case if you are interested to order the adapter in complete set with cutting ring and nut, it is necessary to insert suffix "RN" after our part no., for example ACHC-30-27-30OG/RN.

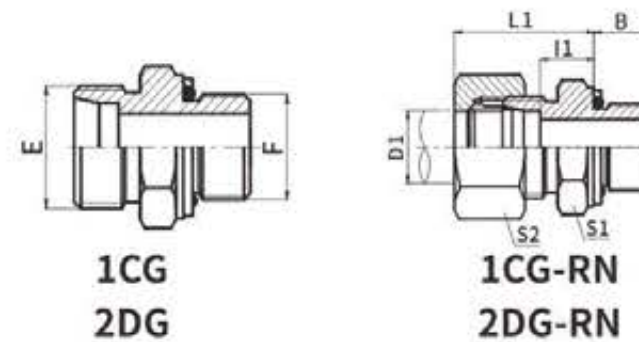

1CG
2DG

1CG-RN
2DG-RN

英管螺纹O形圈密封柱端
BSPP THREAD STUD ENDS
WITH O-RING SEALING

代号 PART NO.	螺纹 THREAD		管子外径 TUBE O.D.	尺寸 DIMENSIONS					压力等级 MPa
	E	F		B	I1	L1	S1	S2	
1CG-12-02	M12X1.5	G1/8"X28	6	9.5	8.5	23	14	14	31.5 轻系列 L
1CG-12-04	M12X1.5	G1/4"X19	6	10	10	25	19	14	
1CG-14-04	M14X1.5	G1/4"X19	8	10	10	25	19	17	
1CG-14-08	M14X1.5	G1/2"X14	8	14	13	27.5	27	34	
1CG-16-04	M16X1.5	G1/4"X19	10	10	11	26	19	19	
1CG-16-06	M16X1.5	G3/8"X19	10	11.5	12.5	27	22	19	
1CG-16-08	M16X1.5	G1/2"X14	10	14	14	29	27	19	
1CG-18-06	M18X1.5	G3/8"X19	12	11.5	12.5	27	22	22	
1CG-18-08	M18X1.5	G1/2"X14	12	14	13	28	27	22	
1CG-22-06	M22X1.5	G3/8"X19	15	11.5	13.5	29	24	27	
1CG-22-08	M22X1.5	G1/2"X14	15	14	14	29	27	27	
1CG-22-12	M22X1.5	G3/4"X14	15	15.5	20	30	32	32	
1CG-26-08	M26X1.5	G1/2"X14	18	14	14.5	31	27	32	
1CG-26-12	M26X1.5	G3/4"X14	18	15.5	14.5	32	32	32	
1CG-30-12	M30X2	G3/4"X14	22	15.5	16.5	33	32	36	16 轻系列 L
1CG-30-16	M30X2	G1"X11	22	18	17.5	35	41	36	
1CG-36-16	M36X2	G1"X11	28	18	17.5	34	41	41	
1CG-45-20	M45X2	G1.1/4"X11	35	20	17.5	39	50	50	
1CG-52-20	M52X2	G1.1/4"X11	42	20	19	42	55	60	
1CG-52-24	M52X2	G1.1/2"X11	42	21.5	19	42	55	60	
1CG-52-32	M52X2	G2"X11	42	24.5	25	44	70	60	
1DG-14-04	M14X1.5	G1/4"X19	6	10	13	28	19	17	
1DG-16-04	M16X1.5	G1/4"X19	8	10	15	31	19	19	
1DG-18-04	M18X1.5	G1/4"X19	10	10	14.5	31	19	22	
1DG-18-06	M18X1.5	G3/8"X19	10	11.5	15	31	22	22	
1DG-20-06	M20X1.5	G3/8"X19	12	11.5	17	32	22	24	
1DG-20-08	M20X1.5	G1/2"X14	12	14	17.5	34	27	24	
1DG-22-06	M22X1.5	G3/8"X19	14	11.5	19	37	24	27	
1DG-22-08	M22X1.5	G1/2"X14	14	14	19	37	27	27	
1DG-24-04	M24X1.5	G1/4"X19	16	11	18	37	27	30	40 重系列 S
1DG-24-08	M24X1.5	G1/2"X14	16	14	18.5	37	27	30	
1DG-30-12	M30X2	G3/4"X14	20	15.5	20.5	42	32	36	
1DG-36-12	M36X2	G3/4"X14	25	15.5	23	47	41	46	
1DG-36-16	M36X2	G1"X11	25	18	17.5	47	41	46	
1DG-42-16	M42X2	G1"X11	30	18	23.5	48	46	50	
1DG-42-20	M42X2	G1.1/4"X11	30	20	23.5	50	50	50	
1DG-52-24	M52X2	G1.1/2"X11	38	21.5	26	57	55	60	

注：如需带卡套及卡套螺母整套订货，请在代号后加“RN”，如1DG-20-08RN。
Note: In case if you are interested to order the adapter in complete set with cutting ring and nut, it is necessary to insert suffix "RN" after our part no., for example 1DG-20-08RN.

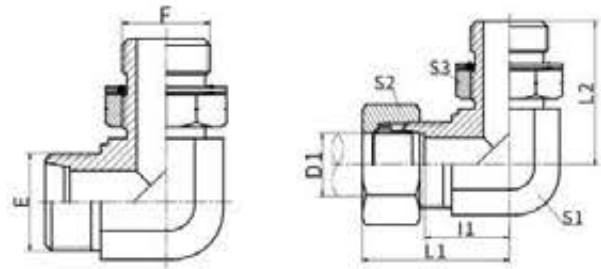
1CG9-OG
1DG9-OG
1CG9-OG/RN
1DG9-OG/RN

90° 弯英管螺纹可调向O形圈密封柱端
 90° ELBOW BSPP THREAD ADJUSTABLE
 STUD ENDS WITH O-RING SEALING

代号 PART NO.	螺纹 THREAD		管子外径TUBE O.D. D1	尺寸 DIMENSIONS						压力等级 MPa
	E	F		I1	L1	L2	S1	S2	S3	
1CG9-12-02OG	M12X1.5	G1/8"X28	6	13	28	26.2	11	14	14	31.5 轻系列 L
1CG9-14-04OG	M14X1.5	G1/4"X19	8	15.5	30.5	31.3	14	17	19	
1CG9-16-04OG	M16X1.5	G1/4"X19	10	17.5	32.5	32.5	16	19	19	
1CG9-16-06OG	M16X1.5	G3/8"X19	10	17.5	32.5	35.8	16	19	22	
1CG9-18-06OG	M18X1.5	G3/8"X19	12	19	34	36.8	19	22	22	
1CG9-22-08OG	M22X1.5	G1/2"X14	15	22	37	43.2	22	27	27	
1CG9-26-08OG	M26X1.5	G1/2"X14	18	25.5	42	46	27	32	27	
1CG9-26-12OG	M26X1.5	G3/4"X14	18	25.5	42	49.3	27	32	32	
1CG9-30-12OG	M30X2	G3/4"X14	22	29.3	45.8	52	30	36	32	
1CG9-30-16OG	M30X2	G1"X11	22	31.5	48	53	33	36	41	
1CG9-36-16OG	M36X2	G1"X11	28	33	49.8	56	36	41	41	
1CG9-36-20OG	M36X2	G1.1/4"X11	28	36	52.8	59	41	41	50	
1CG9-45-20OG	M45X2	G1.1/4"X11	35	39.2	60.7	63	48	50	50	
1CG9-52-24OG	M52X2	G1.1/2"X11	42	44.8	67.8	68.5	55	60	55	
1DG9-14-04OG	M14X1.5	G1/4"X19	6	17.5	32.5	31.3	14	17	19	
1DG9-16-04OG	M16X1.5	G1/4"X19	8	18.7	33.7	32.5	16	19	19	
1DG9-16-06OG	M16X1.5	G3/8"X19	8	18.7	33.7	35.8	16	19	22	
1DG9-18-06OG	M18X1.5	G3/8"X19	10	19.5	36	36.8	19	22	22	
1DG9-20-06OG	M20X1.5	G3/8"X19	12	19.5	36	36.8	19	24	22	
1DG9-22-08OG	M22X1.5	G1/2"X14	14	23	41	43.2	22	27	27	
1DG9-24-08OG	M24X1.5	G1/2"X14	16	24	42.5	43	24	30	27	
1DG9-30-12OG	M30X2	G3/4"X14	20	28	49.5	52	30	36	32	
1DG9-36-16OG	M36X2	G1"X11	25	32.8	56.8	56	36	46	41	
1DG9-42-20OG	M42X2	G1.1/4"X11	30	36.2	62.7	58	41	50	50	
1DG9-52-24OG	M52X2	G1.1/2"X11	38	45.8	76.8	68.5	55	60	55	

注：如需带卡套及卡套螺母整套订货，则请在代号后加“RN”，如1CG9-30-12OG/RN。
 Note: In case if you are interested to order the adapter in complete set with cutting ring and nut, it is necessary to insert suffix "RN" after our part no., for example 1CG9-30-12OG/RN.

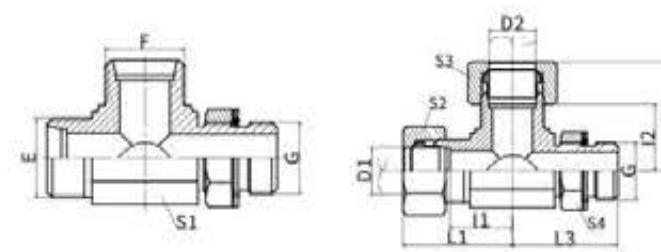
ACCG-OG
ADDG-OG
ACCG-OG/RN
ADDG-OG/RN

英管螺纹可调向O形圈密封柱端主支三通
 BSPP THREAD ADJUSTABLE STUD
 END WITH O-RING SEALING RUN TEE

代号 PART NO.	螺纹 THREAD		管子外径TUBE O.D. D1,D2	尺寸 DIMENSIONS						压力等级 MPa
	E,F	G		I1,I2	L1,L2	L3	S1	S2,S3	S4	
ACCG-12-12-02OG	M12X1.5	G1/8"X28	6	13	28	26.2	11	14	14	31.5 轻系列 L
ACCG-14-14-04OG	M14X1.5	G1/4"X19	8	15.5	30.5	31.3	14	17	19	
ACCG-16-16-04OG	M16X1.5	G1/4"X19	10	17.5	32.5	32.5	17	19	19	
ACCG-18-18-06OG	M18X1.5	G3/8"X19	12	19	34	36.8	19	22	22	
ACCG-22-22-08OG	M22X1.5	G1/2"X14	15	22	37	43.2	22	27	27	
ACCG-26-26-08OG	M26X1.5	G1/2"X14	18	25.5	42	46.5	27	32	27	
ACCG-30-30-12OG	M30X2	G3/4"X14	22	29.3	45.8	52	30	36	32	
ACCG-36-36-16OG	M36X2	G1"X11	28	33.3	49.8	56	36	41	41	
ACCG-45-45-20OG	M45X2	G1.1/4"X11	35	39.2	60.7	63	48	50	50	
ADDG-14-14-04OG	M14X1.5	G1/4"X19	6	17.5	32.5	31.3	14	17	19	
ADDG-16-16-04OG	M16X1.5	G1/4"X19	8	18.7	33.7	32.5	16	19	19	
ADDG-18-18-06OG	M18X1.5	G3/8"X19	10	19.5	36	36.8	19	22	22	
ADDG-20-20-06OG	M20X1.5	G3/8"X19	12	19.5	36	36.8	19	24	22	
ADDG-22-22-08OG	M22X1.5	G1/2"X14	14	23	41	43.2	22	27	27	
ADDG-24-24-08OG	M24X1.5	G1/2"X14	16	24	42.5	44	24	30	27	
ADDG-30-30-12OG	M30X2	G3/4"X14	20	28.3	49.5	52	30	36	32	
ADDG-36-36-16OG	M36X2	G1"X11	25	32.8	56.8	56	36	46	41	
ADDG-42-42-20OG	M42X2	G1.1/4"X11	30	36.2	62.7	58	41	50	50	

注：如需带卡套及卡套螺母整套订货，则请在代号后加“RN”，如ACCG-18-18-06OGRN。
 Note: In case if you are interested to order the adapter in complete set with cutting ring and nut, it is necessary to insert suffix "RN" after our part no., for example ACCG-18-18-06OGRN.

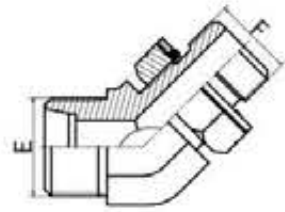
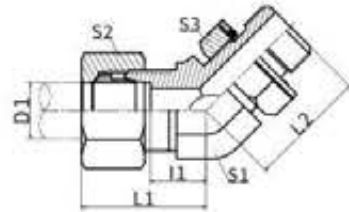
1CG4-OG
1DG4-OG

1CG4-OG/RN
1DG4-OG/RN

**45° 弯英管螺纹可调向
O形圈密封柱端**
**45° ELBOW BSP THREAD ADJUSTABLE
STUD ENDS WITH O-RING SEALING**

代号 PART NO.	螺纹 THREAD		管子外径 TUBE O.D. D1	尺寸 DIMENSIONS						压力等级 MPa
	E	F		I1	L1	L2	S1	S2	S3	
1CG4-12-02OG	M12X1.5	G1/8"X28	6	10	25	24	11	14	14	31.5 轻系列 L
1CG4-14-04OG	M14X1.5	G1/4"X19	8	11	26	27	14	17	19	
1CG4-16-04OG	M16X1.5	G1/4"X19	10	12.3	27.3	27	16	19	19	
1CG4-16-06OG	M16X1.5	G3/8"X19	10	12.3	27.3	30	16	19	22	
1CG4-18-06OG	M18X1.5	G3/8"X19	12	13	28	31	19	22	22	
1CG4-22-08OG	M22X1.5	G1/2"X14	15	15	30	36	22	27	27	
1CG4-26-08OG	M26X1.5	G1/2"X14	18	16.5	33	37.5	27	32	27	
1CG4-26-12OG	M26X1.5	G3/4"X14	18	16.5	33	42	27	32	32	
1CG4-30-12OG	M30X2	G3/4"X14	22	19.7	36.2	42.5	30	36	32	
1CG4-36-16OG	M36X2	G1"X11	28	21.5	38	44.5	36	41	41	
1CG4-45-20OG	M45X2	G1.1/4"X11	35	25.5	47	50.5	48	50	50	
1DG4-14-04OG	M14X1.5	G1/4"X19	6	13	28	27	14	17	19	
1DG4-16-04OG	M16X1.5	G1/4"X19	8	13.3	28.3	27	16	19	19	
1DG4-18-06OG	M18X1.5	G3/8"X19	10	13.5	30	31	19	22	22	
1DG4-20-06OG	M20X1.5	G3/8"X19	12	13.5	30	31	19	24	22	
1DG4-22-08OG	M22X1.5	G1/2"X14	14	16.3	34.3	36	22	27	27	
1DG4-24-08OG	M24X1.5	G1/2"X14	16	16.2	34.7	36.5	24	30	27	
1DG4-30-12OG	M30X2	G3/4"X14	20	18.7	40.2	42.5	30	36	32	
1DG4-36-16OG	M36X2	G1"X11	25	21	45	44.5	36	46	41	
1DG4-42-20OG	M42X2	G1.1/4"X11	30	24.3	50.8	47.5	41	50	50	

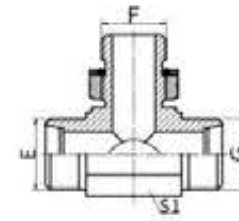
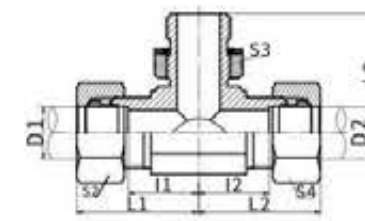
注：如需带卡套及卡套螺母整套订货，则请在代号后加“RN”，如1CG4-30-12OG/RN。
 Note: In case if you are interested to order the adapter in complete set with cutting ring and nut, it is necessary to insert suffix "RN" after our part no., for example 1CG4-30-12OG/RN.

ACGC-OG
ADGD-OG

ACGC-OG/RN
ADGD-OG/RN

英管螺纹可调向O形圈密封柱端分支三通
BSP THREAD ADJUSTABLE STUD ENDS
WITH O-RING SEALING BRANCH TEE

代号 PART NO.	螺纹 THREAD		管子外径 TUBE O.D. D1, D2	尺寸 DIMENSIONS						压力等级 MPa
	E, G	F		I1, I2	L1, L2	L3	S1	S2, S3	S4	
ACGC-12-02-12OG	M12X1.5	G1/8"X28	6	13	28	26.2	11	14	14	31.5 轻系列 L
ACGC-14-04-14OG	M14X1.5	G1/4"X19	8	15.5	30.5	31.3	14	17	19	
ACGC-16-04-16OG	M16X1.5	G1/4"X19	10	17.5	32.5	32.5	16	19	19	
ACGC-18-06-18OG	M18X1.5	G3/8"X19	12	19	34	36.8	19	22	22	
ACGC-22-08-22OG	M22X1.5	G1/2"X14	15	22	37	43.2	22	27	27	
ACGC-26-08-26OG	M26X1.5	G1/2"X14	18	25.5	42	46.5	27	32	27	
ACGC-30-12-30OG	M30X2	G3/4"X14	22	29.3	45.8	52	30	36	32	
ACGC-36-16-36OG	M36X2	G1"X11	28	33.3	49.8	56	36	41	41	
ACGC-45-20-45OG	M45X2	G1.1/4"X11	35	39.2	60.7	63	48	50	50	
ADGD-14-04-14OG	M14X1.5	G1/4"X19	6	17.5	32.5	31.3	14	17	19	
ADGD-16-04-16OG	M16X1.5	G1/4"X19	8	18.7	33.7	32.5	16	19	19	
ADGD-18-06-18OG	M18X1.5	G3/8"X19	10	19.5	36	36.8	19	22	22	
ADGD-20-06-20OG	M20X1.5	G3/8"X19	12	19.5	36	36.8	19	24	22	
ADGD-22-08-22OG	M22X1.5	G1/2"X14	14	23	41	43.2	22	27	27	
ADGD-24-08-24OG	M24X1.5	G1/2"X14	16	24	42.5	44	24	30	27	
ADGD-30-12-30OG	M30X2	G3/4"X14	20	28.3	49.5	52	30	36	32	
ADGD-36-16-36OG	M36X2	G1"X11	25	32.8	56.8	56	36	46	41	
ADGD-42-20-42OG	M42X2	G1.1/4"X11	30	36.2	62.7	58	41	50	50	

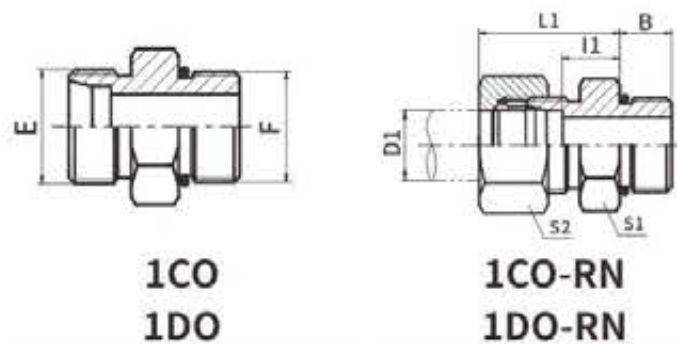
注：如需带卡套及卡套螺母整套订货，则请在代号后加“RN”，如ACGC-18-06-08OG/RN。
 Note: In case if you are interested to order the adapter in complete set with cutting ring and nut, it is necessary to insert suffix "RN" after our part no., for example ACGC-18-06-08OG/RN.

**1CO
1DO**
**1CO-RN
1DO-RN**
**美制螺纹O形圈密封柱端ISO 11926
UN、UNF THREAD STUD ENDS
WITH O-RING SEALING ISO 11926**

代号 PART NO.	螺纹 THREAD		管子外径TUBE O.D. D1	尺寸 DIMENSIONS					压力等级 MPa
	E	F		B	I1	L1	S1	S2	
1CO-14-04	M14X1.5	7/16"X20	8	9	10	25	17	17	31.5 轻系列 L
1CO-16-04	M16X1.5	7/16"X20	10	9	11	26	17	19	
1CO-18-08	M18X1.5	3/4"X16	12	11	13	28	24	22	
1CO-18-10	M18X1.5	7/8"X14	12	12.7	14.3	29	27	22	
1CO-22-08	M22X1.5	3/4"X16	15	11	14	29	24	27	
1CO-22-10	M22X1.5	7/8"X14	15	12.7	15.3	30	27	27	
1CO-22-12	M22X1.5	1.1/16"X12	15	15.09	11.91	30	32	27	
1CO-26-08	M26X1.5	3/4"X16	18	11	14.5	31	27	32	
1CO-26-10	M26X1.5	7/8"X14	18	12.7	14.8	31	27	32	
1CO-30-08	M30X2	3/4"X16	22	11.13	13.87	33	32	36	
1CO-30-10	M30X2	7/8"X14	22	12.7	16.8	33	32	36	
1CO-30-12	M30X2	1.1/16"X12	22	15	16.5	33	32	36	
1CO-30-16	M30X2	1.5/16"X12	22	15	17.5	34	41	36	
1CO-36-12	M36X2	1.1/16"X12	28	15.09	14.41	34	41	41	
1CO-36-16	M36X2	1.5/16"X12	28	15	17.5	34	41	41	
1CO-45-16	M45X2	1.5/16"X12	35	15	17.5	39	46	50	
1CO-45-20	M45X2	1.5/8"X12	35	15.09	16.41	39	50	50	
1CO-52-20	M52X2	1.5/8"X12	42	15.09	15.91	42	55	60	
1DO-16-04	M16X1.5	7/16"X20	8	9	15	30	17	19	63 重系列 S
1DO-18-06	M18X1.5	9/16"X18	10	10	14.5	31	19	22	
1DO-20-06	M20X1.5	9/16"X18	12	10	14.5	31	22	24	
1DO-20-08	M20X1.5	3/4"X16	12	11	17.5	34	24	24	
1DO-24-08	M24X1.5	3/4"X16	16	11	15.5	34	24	30	40 重系列 S
1DO-24-10	M24X1.5	7/8"X14	16	12.7	18.8	37	27	30	
1DO-30-08	M30X2	3/4"X16	20	11	20.5	42	32	36	
1DO-30-10	M30X2	7/8"X14	20	12.7	20.8	42	32	36	
1DO-30-12	M30X2	1.1/16"X12	20	15	20.5	42	32	36	
1DO-36-12	M36X2	1.1/16"X12	25	15.09	19.91	47	41	46	
1DO-36-16	M36X2	1.5/16"X12	25	15	23	47	41	46	
1DO-42-16	M42X2	1.5/16"X12	30	15	23.5	50	46	50	
1DO-42-20	M42X2	1.5/8"X12	30	15	23.5	50	50	50	
1DO-52-20	M52X2	1.5/8"X12	38	15.09	22.9	53.9	55	60	

注：如需带卡套及卡套螺母整套订货，则请在代号后加“RN”，如1DO-30-12RN。
 Note: In case if you are interested to order the adapter in complete set with cutting ring and nut, it is necessary to insert suffix "RN" after our part no., for example 1DO-30-12RN.

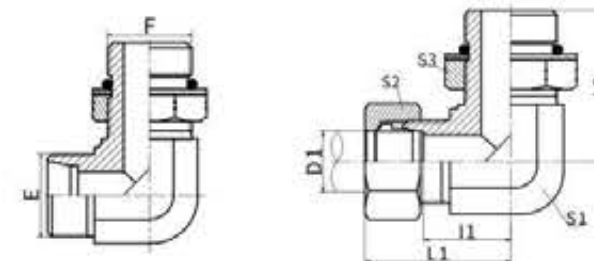
**1CO9-OG
1DO9-OG**
**1CO9-OG/RN
1DO9-OG/RN**
**90° 弯美制螺纹可调向O形圈密封柱端ISO11926
90° ELBOW UN、UNF THREAD ADJUSTABLE
STUD ENDS WITH O-RING SEALING ISO 11926**

代号 PART NO.	螺纹 THREAD		管子外径TUBE O.D. D1	尺寸 DIMENSIONS					压力等级 MPa		
	E	F		I1	L1	L2	S1	S2		S3	
1CO9-12-04OG	M12X1.5	7/16"X20	6	13	28	27.2	11	14	17	31.5 轻系列 L	
1CO9-14-06OG	M14X1.5	9/16"X18	8	15.5	30.5	31.8	14	17	19		
1CO9-18-08OG	M18X1.5	3/4"X16	12	19	34	37.5	19	22	24		
1CO9-22-10OG	M22X1.5	7/8"X14	15	22	37	44	22	27	27		
1CO9-22-08OG	M22X1.5	3/4"X16	15	22	37	39.5	22	27	24		
1CO9-26-12OG	M26X1.5	1.1/16"X12	18	25.5	42	51	27	32	32		
1CO9-30-12OG	M30X2	1.1/16"X12	22	29.3	45.8	53.5	30	36	32		16 轻系列 L
1CO9-36-12OG	M36X2	1.1/16"X12	28	33.5	47.8	57.5	36	41	41		
1CO9-36-16OG	M36X2	1.5/16"X12	28	33.3	49.8	57.5	36	41	41		
1CO9-45-20OG	M45X2	1.5/8"X12	35	39.2	60.7	63	48	50	50		
1CO9-52-24OG	M52X2	1.7/8"X12	42	44.8	67.8	70.5	55	60	55		
1DO9-14-04OG	M14X1.5	7/16"X20	6	17.5	32.5	30	14	17	17	63 重系列 S	
1DO9-16-06OG	M16X1.5	9/16"X18	8	18.7	33.7	33.3	16	19	19		
1DO9-18-06OG	M18X1.5	9/16"X18	10	19.5	36	33.5	19	22	19		
1DO9-18-08OG	M18X1.5	3/4"X16	10	19.5	36	37.5	19	22	24		
1DO9-20-08OG	M20X1.5	3/4"X16	12	19.5	36	37.5	19	24	24		
1DO9-22-10OG	M22X1.5	7/8"X14	14	23	41	44	22	27	27		
1DO9-24-10OG	M24X1.5	7/8"X14	16	24	42.5	46.5	24	30	27	40 重系列 S	
1DO9-30-12OG	M30X2	1.1/16"X12	20	28.3	49.8	53.5	30	36	32		
1DO9-36-16OG	M36X2	1.5/16"X12	25	32.8	56.8	57.5	36	46	41		
1DO9-42-20OG	M42X2	1.5/8"X12	30	36.2	62.7	59.5	41	50	50		
1DO9-52-24OG	M52X2	1.7/8"X12	38	45.8	76.8	70.5	55	60	55		31.5重系列S

注：如需带卡套及卡套螺母整套订货，则请在代号后加“RN”，如1CO9-30-12OG/RN。
 Note: In case if you are interested to order the adapter in complete set with cutting ring and nut, it is necessary to insert suffix "RN" after our part no., for example 1CO9-30-12OG/RN.

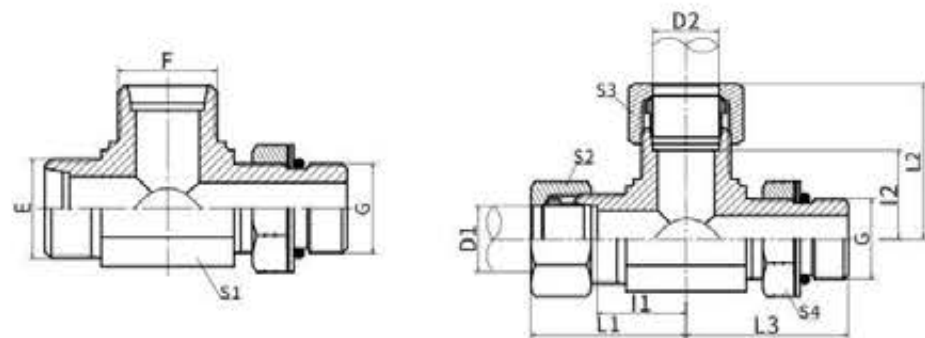
ACCO-OG
ADDO-OG
ACCO-OG/RN
ADDO-OG/RN

美制螺纹可调向O形圈密封柱端主支三通
 UN、UNF THREAD ADJUSTABLE
 STUD ENDS WITH O-RING SEALING RUN TEE

代号 PART NO.	螺纹 THREAD		管子外径TUBE O.D. D1,D2	尺寸 DIMENSIONS						压力等级 MPa
	E,F	G		I1,I2	L1,L2	L3	S1	S2,S3	S4	
ACCO-12-12-04OG	M12X1.5	7/16"X20	6	13	28	27.2	11	14	17	31.5 轻系列 L
ACCO-14-14-06OG	M14X1.5	9/16"X18	8	15.5	30.5	31.8	14	17	19	
ACCO-16-16-06OG	M16X1.5	9/16"X18	10	17.5	32.5	33.3	17	19	19	
ACCO-18-18-08OG	M18X1.5	3/4"X16	12	19	34	37.5	19	22	24	
ACCO-22-22-10OG	M22X1.5	7/8"X14	15	22	37	44	22	27	27	
ACCO-26-26-12OG	M26X1.5	1.1/16"X12	18	25.5	42	51	27	32	32	
ACCO-30-30-12OG	M30X2	1.1/16"X12	22	29.3	45.8	53.5	30	36	32	16 轻系列 L
ACCO-36-36-16OG	M36X2	1.5/16"X12	28	33.3	49.8	57.5	36	41	41	
ACCO-45-45-20OG	M45X2	1.5/8"X12	35	39.2	60.7	63	48	50	50	
ADDO-14-14-04OG	M14X1.5	7/16"X20	6	17.5	32.5	30	14	17	17	63 重系列 S
ADDO-16-16-06OG	M16X1.5	9/16"X18	8	18.7	33.7	33.3	16	19	19	
ADDO-18-18-06OG	M18X1.5	9/16"X18	10	19.5	36	33.5	19	22	19	
ADDO-20-20-08OG	M20X1.5	3/4"X16	12	19.5	36	37.5	19	24	24	
ADDO-22-22-10OG	M22X1.5	7/8"X14	14	23	41	44	22	27	27	
ADDO-24-24-10OG	M24X1.5	7/8"X14	16	24	42.5	46.5	24	30	27	40 重系列 S
ADDO-30-30-12OG	M30X2	1.1/16"X12	20	28.3	49.8	53.5	30	36	32	
ADDO-36-36-16OG	M36X2	1.5/16"X12	25	32.8	56.8	57.5	36	46	41	
ADDO-42-42-20OG	M42X2	1.5/8"X12	30	36.2	62.7	59.5	41	50	50	

注：如需带卡套及卡套螺母整套订货，则请在代号后加“RN”，如ACCO-30-30OG/RN。
 Note: In case if you are interested to order the adapter in complete set with cutting ring and nut, it is necessary to insert suffix "RN" after our part no., for example ACCO-30-30OG/RN.

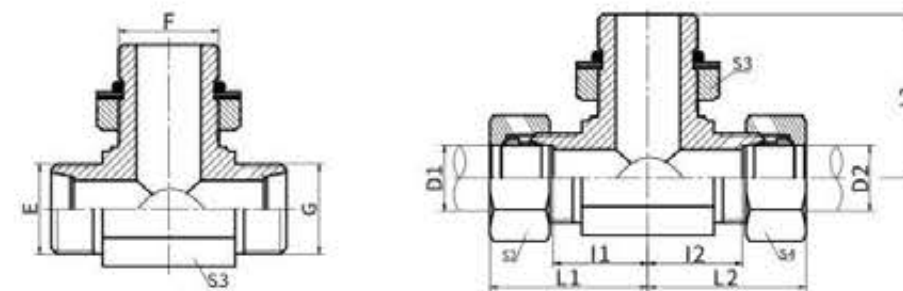
ACOC-OG
ADOD-OG
ACOC-OG/RN
ADOD-OG/RN

美制螺纹可调向O形圈密封柱端分支三通
 UN、UNF THREAD ADJUSTABLE
 STUD ENDS WITH O-RING SEALING BRANCH TEE

代号 PART NO.	螺纹 THREAD		管子外径TUBE O.D. D1,D2	尺寸 DIMENSIONS						压力等级 MPa
	E,G	F		I1,I2	L1,L2	L3	S1	S2,S4	S3	
ACOC-12-04-12OG	M12X1.5	7/16"X20	6	13	28	27.2	11	14	17	31.5 轻系列 L
ACOC-14-06-14OG	M14X1.5	9/16"X18	8	15.5	30.5	31.8	14	17	19	
ACOC-16-06-16OG	M16X1.5	9/16"X18	10	17.5	32.5	33.3	17	19	19	
ACOC-18-08-18OG	M18X1.5	3/4"X16	12	19	34	37.5	19	22	24	
ACOC-22-10-22OG	M22X1.5	7/8"X14	15	22	37	44	22	27	27	
ACOC-26-12-26OG	M26X1.5	1.1/16"X12	18	25.5	42	51	27	32	32	
ACOC-30-12-30OG	M30X2	1.1/16"X12	22	29.3	45.8	53.5	30	36	32	16 轻系列 L
ACOC-36-16-36OG	M36X2	1.5/16"X12	28	33.3	49.8	57.5	36	41	41	
ACOC-45-20-45OG	M45X2	1.5/8"X12	35	39.2	60.7	63	48	50	50	
ADOD-14-04-14OG	M14X1.5	7/16"X20	6	17.5	32.5	30	14	17	17	63 重系列 S
ADOD-16-06-16OG	M16X1.5	9/16"X18	8	18.7	33.7	33.3	16	19	19	
ADOD-18-06-18OG	M18X1.5	9/16"X18	10	19.5	36	33.5	19	22	19	
ADOD-20-08-20OG	M20X1.5	3/4"X16	12	19.5	36	37.5	19	24	24	
ADOD-22-10-22OG	M22X1.5	7/8"X14	14	23	41	44	22	27	27	
ADOD-24-10-24OG	M24X1.5	7/8"X14	16	24	42.5	46.5	24	30	27	40 重系列 S
ADOD-30-12-30OG	M30X2	1.1/16"X12	20	28.3	49.8	53.5	30	36	32	
ADOD-36-16-36OG	M36X2	1.5/16"X12	25	32.8	56.8	57.5	36	46	41	
ADOD-42-20-42OG	M42X2	1.5/8"X12	30	36.2	62.7	59.5	41	50	50	

注：如需带卡套及卡套螺母整套订货，则请在代号后加“RN”，如ACOC-30-12-30OG/RN。
 Note: In case if you are interested to order the adapter in complete set with cutting ring and nut, it is necessary to insert suffix "RN" after our part no., for example ACOC-30-12-30OG/RN.

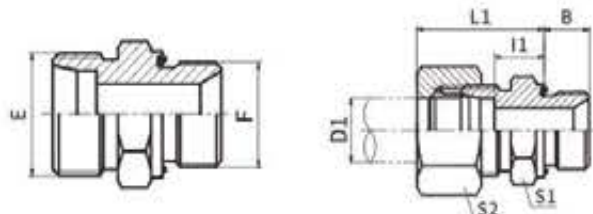
1CB-WD
1DB-WD
1CB-WD/RN
1DB-WD/RN
英管螺纹胶垫密封柱端
BSP THREAD WITH CAPTIVE SEAL

代号 PART NO.	螺纹 THREAD		管子外径 TUBE O.D.	胶垫 SEAL	尺寸 DIMENSIONS					压力等级 MPa	
	E	F			B	I1	L1	S1	S2		
1CB-12-02WD	M12X1.5	G1/8"X28	6	WD-B02	8	8.5	23.5	14	14	31.5 轻系列 L	
1CB-12-04WD	M12X1.5	G1/4"X19	6	WD-B04	12	10	25	19	14		
1CB-14-02WD	M14X1.5	G1/8"X28	8	WD-B02	8	9	24	14	17		
1CB-14-04WD	M14X1.5	G1/4"X19	8	WD-B04	12	10	24	19	17		
1CB-14-06WD	M14X1.5	G3/8"X19	8	WD-B06	12	11	26	22	17		
1CB-16-04WD	M16X1.5	G1/4"X19	10	WD-B04	12	11	24.5	19	19		
1CB-16-06WD	M16X1.5	G3/8"X19	10	WD-B06	12	12.5	26	22	19		
1CB-16-08WD	M16X1.5	G1/2"X14	10	WD-B08	14	13	28	27	19		
1CB-18-04WD	M18X1.5	G1/4"X19	12	WD-B04	12	12	27	19	22		
1CB-18-06WD	M18X1.5	G3/8"X19	12	WD-B06	12	12.5	26	22	22		
1CB-18-08WD	M18X1.5	G1/2"X14	12	WD-B08	14	14	28	27	22		
1CB-22-04WD	M22X1.5	G1/4"X19	15	WD-B04	12	13	28	24	27		
1CB-22-06WD	M22X1.5	G3/8"X19	15	WD-B06	12	13.5	28	24	27		
1CB-22-08WD	M22X1.5	G1/2"X14	15	WD-B08	14	14	29	27	27		
1CB-22-12WD	M22X1.5	G3/4"X14	15	WD-B12	16	15	29	32	27		
1CB-26-08WD	M26X1.5	G1/2"X14	18	WD-B08	14	14.5	31	27	32		
1CB-26-12WD	M26X1.5	G3/4"X14	18	WD-B12	16	14.5	31	32	32		
1CB-30-12WD	M30X2	G3/4"X14	22	WD-B12	16	16.5	33	32	36		
1CB-36-16WD	M36X2	G1"X11	28	WD-B16	18	17.5	34	41	41		
1CB-45-20WD	M45X2	G1.1/4"X11	35	WD-B20	20	17.5	39	50	50		
1CB-52-24WD	M52X2	G1.1/2"X11	42	WD-B24	22	19	42	55	60		
1DB-14-04WD	M14X1.5	G1/4"X19	6	WD-B04	12	15	19	17	63 重系列 S		
1DB-16-04WD	M16X1.5	G1/4"X19	8	WD-B04	12	15	30	19			19
1DB-16-06WD	M16X1.5	G3/8"X19	8	WD-B06	12	15.5	30	22			19
1DB-18-04WD	M18X1.5	G1/4"X19	10	WD-B04	12	14.5	31	19		22	
1DB-18-06WD	M18X1.5	G3/8"X19	10	WD-B06	12	14.5	31	22		22	
1DB-18-08WD	M18X1.5	G1/2"X14	10	WD-B08	14	17.5	34	27		22	
1DB-20-04WD	M20X1.5	G1/4"X19	12	WD-B04	12	16.5	33	22		24	
1DB-20-06WD	M20X1.5	G3/8"X19	12	WD-B06	12	15	33	22		24	
1DB-20-08WD	M20X1.5	G1/2"X14	12	WD-B08	14	17.5	34	27		24	
1DB-22-08WD	M22X1.5	G1/2"X14	14	WD-B08	14	19	37	27		27	
1DB-24-06WD	M24X1.5	G3/8"X19	16	WD-B06	12	18	36.5	27		30	
1DB-24-08WD	M24X1.5	G1/2"X14	16	WD-B08	14	18.5	37	27		30	
1DB-24-12WD	M24X1.5	G3/4"X14	16	WD-B12	16	20.5	39	32	30		
1DB-30-12WD	M30X2	G3/4"X14	20	WD-B12	16	20.5	42	32	36		
1DB-36-08WD	M36X2	G1/2"X14	25	WD-B08	14	23	47	41	46		
1DB-36-12WD	M36X2	G3/4"X14	25	WD-B12	16	23	47	41	46		
1DB-36-16WD	M36X2	G1"X11	25	WD-B16	18	23	47	41	46		
1DB-42-20WD	M42X2	G1.1/4"X11	30	WD-B20	20	23.5	50	50	50		
1DB-52-24WD	M52X2	G1.1/2"X11	38	WD-B24	22	26	57	55	60		

注：如需带卡套及卡套螺母整套订货，则在代号后加“RN”，如1DB-20-08WD/RN。

Note: In case if you are interested to order the adapter in complete set with cutting ring and nut, it is necessary to insert suffix "RN" after our part no., for example 1DB-20-08WD/RN.

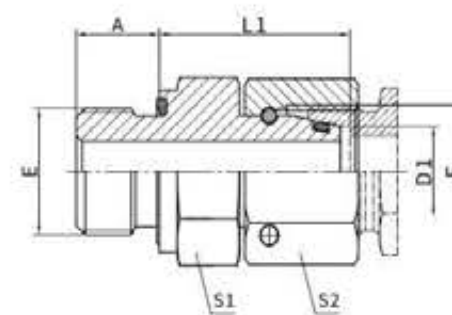
2BC-WD
2BD-WD
英管螺纹胶垫密封柱端 /
公制内螺纹24°锥O形圈密封
BSP THREAD WITH CAPTIVE SEAL /
METRIC FEMALE 24° CONE O-RING SEALING

代号 PART NO.	螺纹 THREAD		管子外径D1 TUBE O.D.	胶垫 SEAL	尺寸 DIMENSIONS				压力等级 MPa
	E	F			A	L1	S1	S2	
2BC-02-12WD	G1/8"X28	M12X1.5	6	WD-B02	8	24.5	14	14	31.5 轻系列 L
2BC-04-14WD	G1/4"X19	M14X1.5	8	WD-B04	12	25	19	17	
2BC-04-16WD	G1/4"X19	M16X1.5	10	WD-B04	12	27.5	19	19	
2BC-06-18WD	G3/8"X19	M18X1.5	12	WD-B06	12	34	22	22	
2BC-08-22WD	G1/2"X14	M22X1.5	15	WD-B08	14	32	27	27	
2BC-08-26WD	G1/2"X14	M26X1.5	18	WD-B08	14	31.5	27	32	
2BC-12-30WD	G3/4"X14	M30X2	22	WD-B12	16	32.5	32	36	
2BC-16-36WD	G1"X11	M36X2	28	WD-B16	18	35	41	41	
2BC-20-45WD	G1.1/4"X11	M45X2	35	WD-B20	20	42.5	50	50	
2BC-24-52WD	G1.1/2"X11	M52X2	42	WD-B24	22	46.5	55	60	
2BD-04-14WD	G1/4"X19	M14X1.5	6	WD-B04	12	27	19	17	63 重系列 S
2BD-04-16WD	G1/4"X19	M16X1.5	8	WD-B04	12	29.5	19	19	
2BD-06-18WD	G3/8"X19	M18X1.5	10	WD-B06	12	32	22	22	
2BD-06-20WD	G3/8"X19	M20X1.5	12	WD-B06	12	34	22	24	
2BD-08-22WD	G1/2"X14	M22X1.5	14	WD-B08	14	36.5	27	27	
2BD-08-24WD	G1/2"X14	M24X1.5	16	WD-B08	14	37	27	30	40 重系列 S
2BD-12-30WD	G3/4"X14	M30X2	20	WD-B12	16	43	32	36	
2BD-16-36WD	G1"X11	M36X2	25	WD-B16	18	48	41	46	
2BD-20-42WD	G1.1/4"X11	M42X2	30	WD-B20	20	51	50	50	
2BD-24-52WD	G1.1/2"X11	M52X2	38	WD-B24	22	60	55	60	

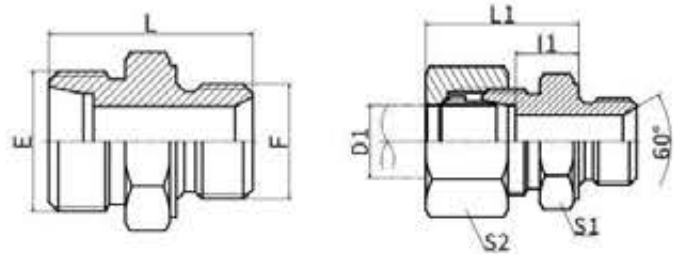
**1CM
1DM**
**1CM-RN
1DM-RN**

公制外螺纹60° 锥密封或
组合垫密封两用柱端
METRIC MALE 60° SEAT SEALING
OR BONDED SEAL STUD ENDS

代号 PART NO.	螺纹 THREAD		管子外径 TUBE O.D. D1	尺寸 DIMENSIONS					压力等级 MPa	
	E	F		B	I1	L1	S1	S2		
1CM-12-10	M12X1.5	M10X1	6	8	8.5	23	14	14	31.5 轻系列 L	
1CM-14-12	M14X1.5	M12X1.5	8	12	10	25	17	17		
1CM-14-18	M14X1.5	M18X1.5	8	12	11.5	26	24	17		
1CM-16-14	M16X1.5	M14X1.5	10	12	11	26	19	19		
1CM-16	M16X1.5	M16X1.5	10	12	12	27	22	19		
1CM-16-18	M16X1.5	M18X1.5	10	12	12.5	27	24	19		
1CM-16-22	M16X1.5	M22X1.5	10	14	14	29	27	19		
1CM-18-14	M18X1.5	M14X1.5	12	12	11	26	19	22		
1CM-18-16	M18X1.5	M16X1.5	12	12	12	27	22	22		
1CM-18	M18X1.5	M18X1.5	12	12	12.5	27	24	22		
1CM-18-22	M18X1.5	M22X1.5	12	14	14	29	27	22		
1CM-22-16	M22X1.5	M16X1.5	15	12	13	28	24	27		
1CM-22-18	M22X1.5	M18X1.5	15	12	13.5	29	24	27		
1CM-22	M22X1.5	M22X1.5	15	14	15	30	27	27		
1CM-26-18	M26X1.5	M18X1.5	18	12	14	30	27	32		
1CM-26-22	M26X1.5	M22X1.5	18	14	14.5	31	27	32		
1CM-30-22	M30X2	M22X1.5	22	14	16.5	33	32	36		16 轻系列 L
1CM-30-26	M30X2	M26X1.5	22	16	16.5	33	32	36		
1CM-30-27	M30X2	M27X2	22	16	18.5	35	32	36		
1CM-36-33	M36X2	M33X2	28	18	17.5	34	41	41		
1CM-45-42	M45X2	M42X2	35	20	17.5	39	50	50		
1CM-52-48	M52X2	M48X2	42	22	19	42	55	60		
1DM-14-12	M14X1.5	M12X1.5	6	12	13	28	17	17	63 重系列 S	
1DM-16-14	M16X1.5	M14X1.5	8	12	15	30	19	19		
1DM-18-16	M18X1.5	M16X1.5	10	12	15	31	22	22		
1DM-20-18	M20X1.5	M18X1.5	12	12	17	33	24	24		
1DM-20-22	M20X1.5	M22X1.5	12	14	17.5	34	27	24		
1DM-22-20	M22X1.5	M20X1.5	14	14	19	37	27	27		
1DM-24-18	M24X1.5	M18X1.5	16	12	18	36	27	30	40 重系列 S	
1DM-24-22	M24X1.5	M22X1.5	16	14	18.5	37	27	30		
1DM-30-27	M30X2	M27X2	20	16	20.5	42	32	36		
1DM-36-33	M36X2	M33X2	25	18	23	47	41	46		
1CM-42	M42X2	M42X2	25	20	23.5	50	50	50		25 重系列S
1DM-52-48	M52X2	M48X2	38	22	57	55	60	60		

注：如需带卡套及卡套螺母整套订货，则请在代号后加“RN”，如1DM-20-18RN。
 Note: In case if you are interested to order the adapter in complete set with cutting ring and nut, it is necessary to insert suffix "RN" after our part no., for example 1DM-20-18RN.

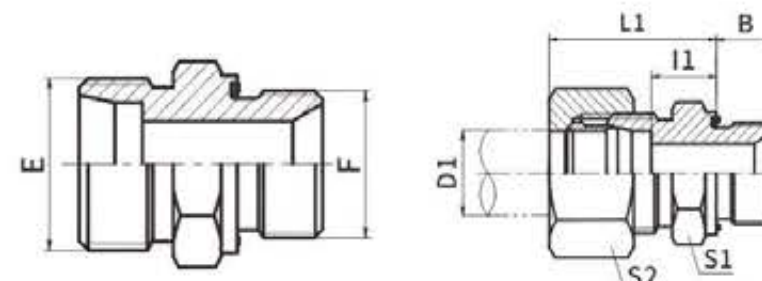
**1CM-WD
1DM-WD**
**1CM-WD/RN
1DM-WD/RN**

公制螺纹胶垫密封柱端
METRIC THREAD WITH
CAPTIVE SEAL

代号 PART NO.	螺纹 THREAD		管子外径 TUBE O.D.	胶垫 SEAL	尺寸 DIMENSIONS					压力等级 MPa	
	E	F			B	I1	L1	S1	S2		
1CM-12-10WD	M12X1.5	M10X1	6	WD-B02	8	8.5	23	14	14	31.5 轻系列 L	
1CM-14-12WD	M14X1.5	M12X1.5	8	WD-M12	12	10	25	17	17		
1CM-16-14WD	M16X1.5	M14X1.5	10	WD-B04	12	11	26	19	19		
1CM-16-18WD	M16X1.5	M18X1.5	10	WD-M18	12	12.5	27	24	19		
1CM-18-16WD	M18X1.5	M16X1.5	12	WD-M16	12	12.5	27	22	22		
1CM-18WD	M18X1.5	M18X1.5	12	WD-M18	12	12.5	27	24	22		
1CM-18-22WD	M18X1.5	M22X1.5	12	WD-M22	14	14	29	27	22		
1CM-22-18WD	M22X1.5	M18X1.5	15	WD-M18	12	13.5	29	24	27		
1CM-22WD	M22X1.5	M22X1.5	15	WD-M22	14	15	30	27	27		
1CM-26-22WD	M26X1.5	M22X1.5	18	WD-M22	14	14.5	31	27	32		
1CM-30-26WD	M30X2	M26X1.5	22	WD-B12	16	16.5	33	32	36		16 轻系列 L
1CM-30-27WD	M30X2	M27X2	22	WD-B12	16	16.5	33	32	36		
1CM-36-33WD	M36X2	M33X2	28	WD-B16	18	17.5	34	41	41		
1CM-45-42WD	M45X2	M42X2	35	WD-B20	20	17.5	39	50	50		
1CM-52-48WD	M52X2	M48X2	42	WD-B24	22	19	42	55	60		
1DM-14-12WD	M14X1.5	M12X1.5	68	WD-M12	12	13	28	17	17	63 重系列 S	
1DM-16-14WD	M16X1.5	M14X1.5	10	WD-B04	12	15	30	19	19		
1DM-18-16WD	M18X1.5	M16X1.5	12	WD-M16	12	15	31	22	22		
1DM-20-18WD	M20X1.5	M18X1.5	14	WD-M18	12	17	33	24	24		
1DM-22-20WD	M22X1.5	M20X1.5	16	WD-M20	14	19	37	27	27	40 重系列 S	
1DM-24-22WD	M24X1.5	M22X1.5	20	WD-M22	14	18.5	37	27	30		
1DM-30-27WD	M30X2	M27X2	25	WD-B12	16	20.5	42	32	36		
1DM-36-33WD	M36X2	M33X2	30	WD-B16	18	23	47	41	46		
1DM-42WD	M42X2	M42X2	38	WD-B20	20	23.5	50	50	50		
1DM-52-48WD	M52X2	M48X2		WD-B24	22	26	57	55	60		31.5重系列S

注：如需带卡套及卡套螺母整套订货，则请在代号后加“RN”，如1DM-20-18WD/RN。
 Note: In case if you are interested to order the adapter in complete set with cutting ring and nut, it is necessary to insert suffix "RN" after our part no., for example 1DM-20-18WD/RN.

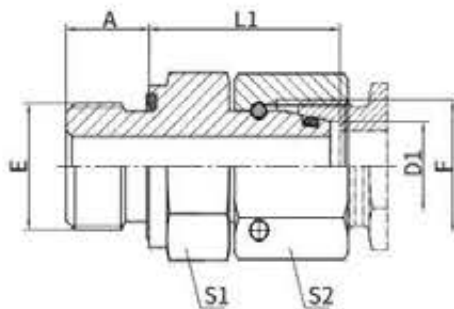

2MC-WD
2MD-WD

公制螺纹胶垫密封柱端 /
公制内螺纹24°锥O形圈密封
METRIC THREAD WITH CAPTIVE SEAL /
METRIC FEMALE 24° CONE O-RING SEALING

代号 PART NO.	螺纹 THREAD		管子外径D1 TUBE O.D.	胶垫 SEAL	尺寸 DIMENSIONS				压力等级 MPa
	E	F			A	I1	S1	S2	
2MC-10-12WD	M10X1	M12X1.5	6	WD-B02	8	24.5	14	14	31.5 轻系列 L
2MC-12-14WD	M12X1.5	M14X1.5	8	WD-M12	12	26.5	17	17	
2MC-14-16WD	M14X1.5	M16X1.5	10	WD-B04	12	27.5	19	19	
2MC-16-18WD	M16X1.5	M18X1.5	12	WD-M16	12	30.5	22	22	
2MC-18-22WD	M18X1.5	M22X1.5	15	WD-M18	12	31.5	24	27	
2MC-22-26WD	M22X1.5	M26X1.5	18	WD-M22	14	31.5	27	32	
2MC-26-30WD	M26X1.5	M30X2	22	WD-M22	16	32.5	32	36	
2MC-33-36WD	M33X2	M36X2	28	WD-B16	18	35	41	41	16 轻系列 L
2MC-42-45WD	M42X2	M45X2	35	WD-B20	20	42.5	50	50	
2MC-48-52WD	M48X2	M52X2	42	WD-B24	22	46.5	55	60	
2MD-12-14WD	M12X1.5	M14X1.5	6	WD-M12	12	27	17	17	63 重系列 S
2MD-14-16WD	M14X1.5	M16X1.5	8	WD-B04	12	29.5	19	19	
2MD-16-18WD	M16X1.5	M18X1.5	10	WD-M16	12	32	22	22	
2MD-18-20WD	M18X1.5	M20X1.5	12	WD-M18	12	34	24	24	
2MD-20-22WD	M20X1.5	M22X1.5	14	WD-M20	14	36.5	27	27	
2MD-22-24WD	M22X1.5	M24X1.5	16	WD-M22	14	37	27	30	40 重系列 S
2MD-27-30WD	M27X2	M30X2	20	WD-B12	16	43	32	36	
2MD-33-36WD	M33X2	M36X2	25	WD-B16	18	48	41	46	
2MD-42-42WD	M42X2	M42X2	30	WD-B20	20	51	50	50	
2MD-48-52WD	M48X2	M52X2	38	WD-B24	22	60	55	60	

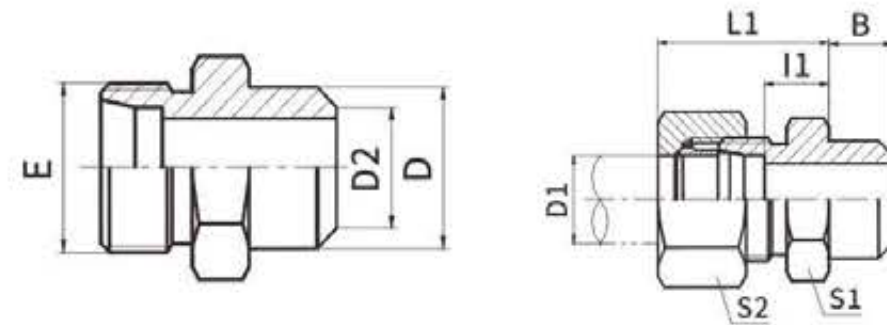

1CW
1DW

1CW-RN
1DW-RN

焊接接头
WELD FITTINGS

代号 PART NO.	螺纹 THREAD		管子外径TUBE O.D.		尺寸 DIMENSIONS					压力等级 MPa	
	E		D1	D2	B	D	I1	L1	S1		S2
1CW-12-06	M12X1.5		6	6	7	10	7	22	12	14	31.5 轻系列 L
1CW-14-08	M14X1.5		8	8	8	12	8	23	14	17	
1CW-16-10	M16X1.5		10	10	8	14	9	24	17	19	
1CW-18-12	M18x1.5		12	12	8	16	10	25	19	22	
1CW-22-15	M22X1.5		15	15	10	19	11	26	22	27	
1CW-26-18	M26X1.5		18	18	10	22	11.5	28	27	32	
1CW-26-22	M26X1.5		18	22	10	27	13.5	28	27	32	16 轻系列 L
1CW-30-22	M30X2		22	22	12	27	13.5	30	32	36	
1CW-36-28	M36X2		28	28	12	32	16.5	33	38	41	
1CW-45-35	M45X2		35	35	14	40	14.5	36	46	50	
1CW-52-42	M52X2		42	42	16	46	16	39	55	60	
1DW-14-06	M14X1.5		6	6	7	11	11	26	14	17	63 重系列 S
1DW-16-08	M16X1.5		8	8	8	13	13	28	17	19	
1DW-18-10	M18X1.5		10	10	8	15	12.5	29	19	22	
1DW-20-12	M20X1.5		12	12	10	17	14.5	31	22	24	
1DW-22-14	M22X1.5		14	14	10	19	16	34	24	27	
1DW-24-16	M24X1.5		16	16	10	21	15.5	34	27	30	
1DW-30-20	M30X2		20	20	12	26	17.5	39	32	36	40 重系列 S
1DW-36-25	M36X2		25	25	12	31	20	44	41	46	
1DW-42-30	M42X2		30	30	14	36	20.5	47	46	50	
1DW-52-38	M52X2		38	38	16	44	23	54	55	60	

注：如需带卡套及卡套螺母整套订货，则请在代号后加“RN”，如1DW-20-12RN。

Note: In case if you are interested to order the adapter in complete set with cutting ring and nut, it is necessary to insert suffix "RN" after our part no., for example 1DW-20-12RN.

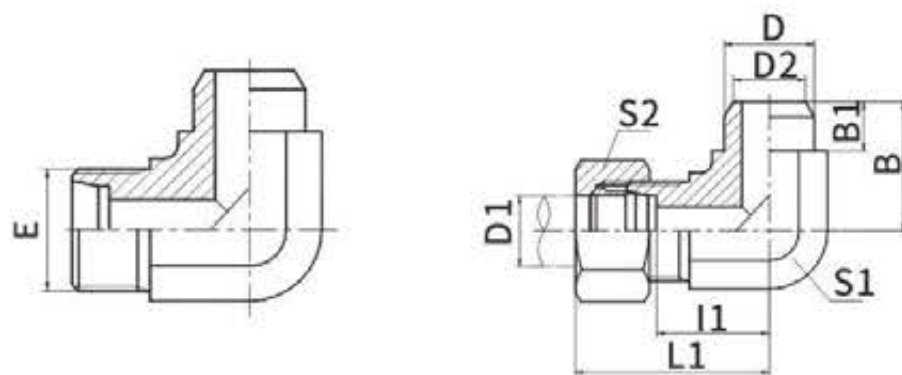

1CW9
1DW9

1CW9-RN
1DW9-RN

90° 焊接接头
90° WELD FITTINGS

代号 PART NO.	螺纹 THREAD	管子外径 TUBE O.D.	尺寸 DIMENSIONS								压力等级 MPa
	E	D1	D2	B	B1	D	I1	L1	S1	S2	
1CW9-12-06	M12X1.5	6	6	15	7	10	13	28	11	14	31.5 轻系列 L
1CW9-14-08	M14X1.5	8	8	18.5	8	12	15.5	30.5	14	17	
1CW9-16-10	M16X1.5	10	10	19.5	8	14	17.5	32.5	16	19	
1CW9-18-12	M18X1.5	12	12	21	8	16	19	34	19	22	
1CW9-22-15	M22X1.5	15	15	25.5	10	19	22	37	22	27	
1CW9-26-18	M26X1.5	18	18	28	10	22	25.5	42	27	32	
1CW9-26-22	M26X1.5	18	22	28	10	27	25.5	42	27	32	
1CW9-30-22	M30X2	22	22	32	12	27	29.3	45.8	30	36	16 轻系列 L
1CW9-30-25	M30X2	22	25	32	12	31	29.3	45.8	30	36	
1CW9-36-28	M36X2	28	28	35.5	12	32	36	52.8	36	41	
1CW9-45-35	M45X2	35	35	45	14	40	39.2	60.7	48	50	
1CW9-52-42	M52X2	42	42	48.5	16	46	40.5	63.5	50	60	
1DW9-14-06	M14X1.5	6	6	17.5	7	11	17.5	32.5	14	17	63 重系列 S
1DW9-16-08	M16X1.5	8	8	19.5	8	13	18.7	33.7	16	19	
1DW9-18-10	M18X1.5	10	10	21	8	15	19.5	36	19	22	
1DW9-20-12	M20X1.5	12	12	23	10	17	19.5	36	19	24	
1DW9-22-14	M22X1.5	14	14	25.5	10	19	23	41	22	27	
1DW9-24-16	M24X1.5	16	16	26.5	10	21	24	42.5	24	30	40 重系列 S
1DW9-30-20	M30X2	20	20	32	12	26	28	49.5	30	36	
1DW9-36-25	M36X2	25	25	35.5	12	31	32.8	56.8	36	46	
1DW9-42-30	M42X2	30	30	39.5	14	36	36.2	62.7	41	50	
1DW9-52-38	M52X2	38	38	48.5	16	44	41.5	72.5	50	60	

注：如需带卡套及卡套螺母整套订货，则请在代号后加“RN”，如1DW9-20-12/RN。
Note: In case if you are interested to order the adapter in complete set with cutting ring and nut, it is necessary to insert suffix "RN" after our part no., for example 1DW9-20-12/RN.

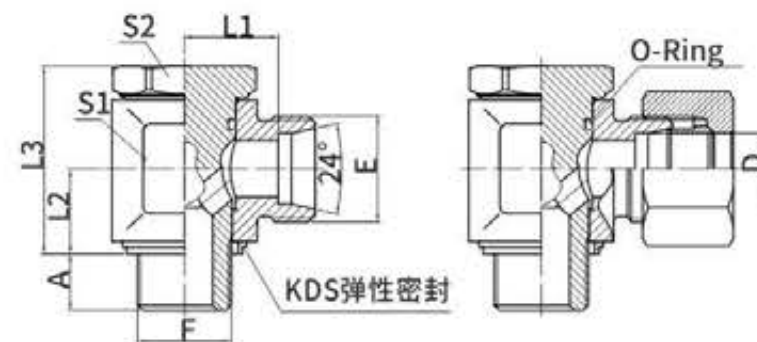

1CI
1DI

1CI-RN
1DI-RN

公制螺纹铰接接头
METRIC BANJO

代号 PART NO.	螺纹 THREAD	管子外径 D	尺寸 DIMENSIONS							压力等级 MPa
	F	E	TUBE O.D.	A	L1	L2	L3	S1	S2	
1CI-12-10	M10X1	M12X1.5	L6	8	12	10.5	24	17	17	31.5 轻系列 L
1CI-14-12	M12X1.5	M14X1.4	L8	12	14.5	14	30	22	19	
1CI-16-14	M14X1.5	M16X1.5	L10	12	15.5	14	30	22	19	
1CI-18-16	M16X1.5	M18X1.5	L12	12	18	16.5	36	27	24	
1CI-22-18	M18X1.5	M22X1.5	L15	12	21.5	18.5	39.5	30	30	
1CI-26-22	M22X1.5	M26X1.5	L18	14	21	21.5	45	32	30	
1CI-30-26	M26X1.5	M30X2	L22	16	27.5	24	53	41	36	
1CI-36-33	M33X2	M36X2	L28	18	32	30.5	66	50	46	
1CI-45-42	M42X2	M45X2	L35	20	36	35.5	76	60	55	
1CI-52-48	M48X2	M52X2	L42	22	40.5	40.5	87	70	60	
1DI-16-14	M14X1.5	M16X1.5	S8	12	16.5	14	30	22	19	40 重系列 S
1DI-18-16	M16X1.5	M18X1.5	S10	12	18.5	16.5	36	27	24	
1DI-20-18	M18X1.5	M20X1.5	S12	12	20	18.5	39.5	27	27	
1DI-22-20	M20X1.5	M22X1.5	S14	14	22.5	20	43.5	32	30	31.5 重系列 S
1DI-24-22	M22X1.5	M24X1.5	S16	14	22	21.5	45	32	30	
1DI-30-27	M27X2	M30X2	S20	16	26.5	24	53	41	36	
1DI-36-33	M33X2	M36X2	S25	18	31.5	30.5	66	50	46	25重系列S
1DI-42-42	M42X2	M42X2	S30	20	37	35.5	76	60	55	
1DI-52-48	M48X2	M52X2	S38	22	41.5	40.5	87	70	60	

注：如需带卡套及卡套螺母整套订货，则请在代号后加“RN”，如1DI-30-26RN。
Note: In case if you are interested to order the adapter in complete set with cutting ring and nut, it is necessary to insert suffix "RN" after our part no., for example 1DI-30-26RN.

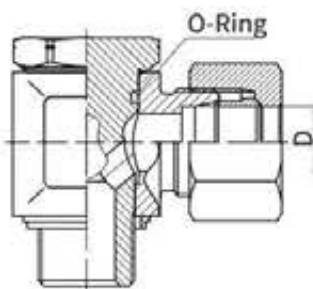
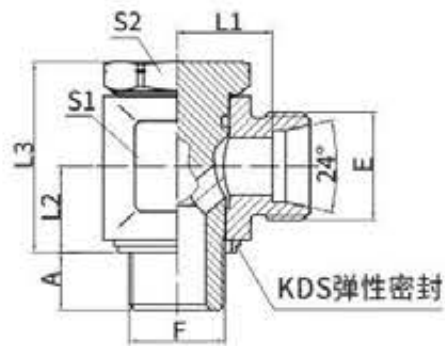

1CI-B
1DI-B

1CI-B/RN
1DI-B/RN

英管螺纹铰接头
BSP BANJO

代号 PART NO.	螺纹 THREAD		管子外径 TUBE O.D.	尺寸 DIMENSIONS						压力等级 MPa
	F	E		A	L1	L2	L3	S1	S2	
1CI-12-B02	G1/8"X28	M12X1.5	L6	8	12	10.5	24	17	17	31.5 轻系列 L
1CI-14-B04	G1/4"X19	M14X1.5	L8	12	14.5	14	30	22	19	
1CI-16-B04	G1/4"X19	M16X1.5	L10	12	15.5	14	30	22	19	
1CI-18-B06	G3/8"X19	M18X1.5	L12	12	18	16.5	36	27	24	
1CI-22-B08	G1/2"X14	M22X1.5	L15	14	21.5	21.5	45	32	30	
1CI-26-B08	G1/2"X14	M26X1.5	L18	14	21	21.5	45	32	30	
1CI-30-B12	G3/4"X14	M30X2	L22	16	27.5	24	53	41	36	16 轻系列 L
1CI-36-B16	G1"X11	M36X2	L28	18	32	30.5	66	50	46	
1CI-45-B20	G1.1/4"X11	M45X2	L35	20	36	35.5	76	60	55	
1CI-52-B24	G1.1/2"X11	M52X2	L42	22	40.5	40.5	87	70	60	
1DI-14-B04	G1/4"X19	M14X1.5	S6	12	16.5	14	30	22	19	40 重系列 S
1DI-16-B04	G1/4"X19	M16X1.5	S8	12	16.5	14	30	22	19	
1DI-18-B06	G3/8"X19	M18X1.5	S10	12	18.5	16.5	36	27	24	
1DI-20-B06	G3/8"X19	M20X1.5	S12	12	18.5	16.5	36	27	24	
1DI-22-B08	G1/2"X14	M22X1.5	S14	14	22.5	21.5	45	32	30	31.5 重系列 S
1DI-24-B08	G1/2"X14	M24X1.5	S16	14	22	21.5	45	32	30	
1DI-30-B12	G3/4"X14	M30X2	S20	16	26.5	24	53	41	36	
1DI-36-B16	G1"X11	M36X2	S25	18	31.5	30.5	66	50	46	
1DI-42-B20	G1.1/4"X11	M42X2	S30	20	37	34.5	76	60	55	25重系列S 16 重系列 S
1DI-52-B24	G1.1/2"X11	M52X2	S38	22	41.5	40.5	87	70	60	

注：如需带卡套及卡套螺母整套订货，则请在代号后加“RN”，如1DI-30-B12/RN。
Note: In case if you are interested to order the adapter in complete set with cutting ring and nut, it is necessary to insert suffix "RN" after our part no., for example 1DI-30-B12/RN.

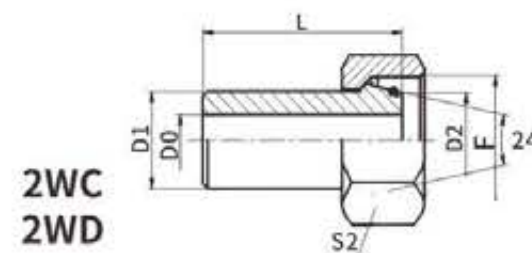

2WC
2WD

焊接接头
WELD FITTINGS

代号 PART NO.	螺纹 THREAD F	管子尺寸 TUBE SIZE D1xt	尺寸 DIMENSIONS				压力等级 MPa
			L	D0	D2	S2	
2WC-6X1.5	M12X1.5	6X1.5	30	2.5	6	14	25 轻系列 L
2WC-8X2.0	M14X1.5	8X2.0	30	4	8	17	
2WC-10X2.0	M16X1.5	10X2.0	31	6	10	19	
2WC-12X2.0	M18X1.5	12X2.0	31	7.5	12	22	
2WC-15X2.0	M22X1.5	15X2.0	35	10	15	27	
2WC-18X2.0	M26X1.5	18X2.0	35	13	18	32	
2WC-22X2.0	M30X2	22X2.0	35	17	22	36	16 轻系列 L
2WC-28X2.5	M36X2	28X2.5	41	23	28	41	
2WC-35X3.0	M45X2	35X3.0	48	29	35	50	
2WC-42X3.0	M52X2	42X3.0	50.5	36	42	60	
2WD-6X1.5	M14X1.5	6X1.5	28.5	2.5	6	17	63 重系列 S
2WD-8X2.0	M16X1.5	8X2.0	29	4	8	19	
2WD-10X1.0	M18X1.5	10X1.0	32	6.5	10	22	
2WD-10X1.5	M18X1.5	10X1.5	32	6.5	10	22	
2WD-10X2.0	M18X1.5	10X2.0	32	6	10	22	
2WD-12X1.5	M20X1.5	12X1.5	32.5	8	12	27	
2WD-12X2.0	M20X1.5	12X2.0	32.5	8	12	27	
2WD-12X2.5	M20X1.5	12X2.5	32.5	7	12	27	
2WD-16X1.5	M24X1.5	16X1.5	39	13	16	30	40 重系列 S
2WD-16X2.0	M24X1.5	16X2.0	39	12	16	30	
2WD-16X2.5	M24X1.5	16X2.5	39	11	16	30	
2WD-16X3.0	M24X1.5	16X3.0	39	10	16	30	
2WD-20X2.0	M30X2	20X2.0	43	15	20	36	
2WD-20X2.5	M30X2	20X2.5	43	15	20	36	
2WD-20X3.0	M30X2	20X3.0	43	14	20	36	
2WD-20X4.0	M30X2	20X4.0	43	12	20	36	
2WD-25X2.5	M36X2	25X2.5	50	20	25	46	
2WD-25X3.0	M36X2	25X3.0	50	19	25	46	
2WD-25X4.0	M36X2	25X4.0	50	17	25	46	
2WD-25X5.0	M36X2	25X5.0	50	15	25	46	
2WD-30X3.0	M42X2	30X3.0	52	24	30	50	25 重系列 S
2WD-30X4.0	M42X2	30X4.0	52	22	30	50	
2WD-30X5.0	M42X2	30X5.0	52	20	30	50	
2WD-30X6.0	M42X2	30X6.0	52	18	30	50	
2WD-38X4.0	M52X2	38X4.0	56.5	30	38	60	
2WD-38X5.0	M52X2	38X5.0	56.5	28	38	60	
2WD-38X6.0	M52X2	38X6.0	56.5	26	38	60	
2WD-38X7.0	M52X2	38X7.0	56.5	24	38	60	

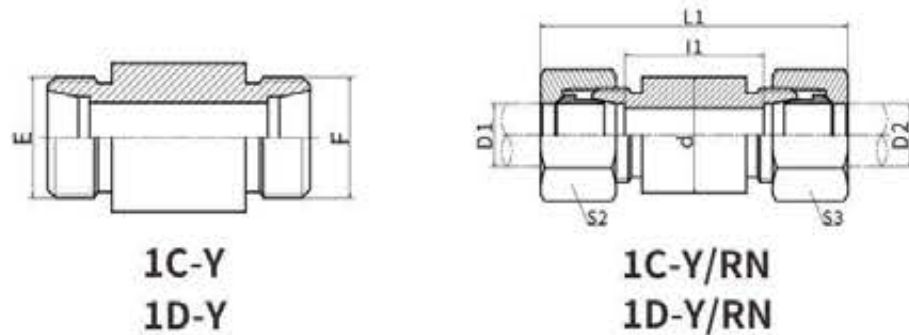

圆柱过板接头
CYLINDER STRAIGHT BULKHEAD

代号 PART NO.	螺纹 THREAD		管子外径 TUBE O.D.		尺寸 DIMENSIONS				压力等级 MPa
	E	F	D1	D2	I1	L1	d	S2,S3	
1C-12Y	M12X1.5	M12X1.5	6	6	56	85	18	14	31.5 轻系列 L
1C-14Y	M14X1.5	M14X1.5	8	8	56	85	20	17	
1C-16Y	M16X1.5	M16X1.5	10	10	58	87	22	19	
1C-18Y	M18X1.5	M18X1.5	12	12	58	87	25	22	
1C-22Y	M22X1.5	M22X1.5	15	15	70	100	28	27	
1C-26Y	M26X1.5	M26X1.5	18	18	69	101	32	32	
1C-30Y	M30X2	M30X2	22	22	73	105	36	36	16 轻系列 L
1C-36Y	M36X2	M36X2	28	28	73	106	40	41	
1C-45Y	M45X2	M45X2	35	35	71	114	50	50	
1C-52Y	M52X2	M52X2	42	42	70	115	60	60	
1D-14Y	M14X1.5	M14X1.5	6	6	60	89	20	17	63 重系列 S
1D-16Y	M16X1.5	M16X1.5	8	8	60	89	22	19	
1D-18Y	M18X1.5	M18X1.5	10	10	59	91	25	22	
1D-20Y	M20X1.5	M20X1.5	12	12	59	91	28	24	
1D-22Y	M22X1.5	M22X1.5	14	14	72	107	30	27	
1D-24Y	M24X1.5	M24X1.5	16	16	71	107	35	30	40 重系列 S
1D-30Y	M30X2	M30X2	20	20	71	114	38	36	
1D-36Y	M36X2	M36X2	25	25	72	120	45	46	
1D-42Y	M42X2	M42X2	30	30	73	126	50	50	
1D-52Y	M52X2	M52X2	38	38	72	133	60	60	

注：如需带卡套及卡套螺母整套订货，则请在代号后加“RN”，如1D-36Y/RN。
 Note: In case if you are interested to order the adapter in complete set with cutting ring and nut, it is necessary to insert suffix "RN" after our part no., for example 1D-36Y/RN.

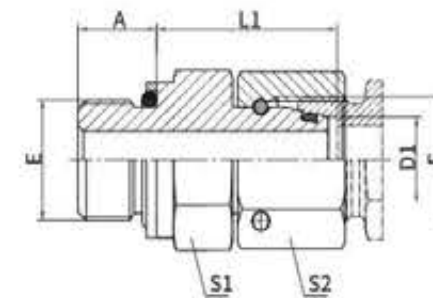

2GC
2GD

**英管螺纹O形圈密封柱端/
 公制内螺纹24°锥O形圈密封**
**BSP THREAD STUD ENDS WITH O-RING SEALING /
 METRIC FEMALE 24° CONE O-RING SEALING**

代号 PART NO.	螺纹 THREAD		管子外径 TUBE O.D. D1	尺寸 DIMENSIONS				压力等级 MPa
	E	F		A	L1	S1	S2	
2GC-02-12	G1/8"X28	M12X1.5	6	9.5	20.5	14	14	31.5 轻系列 L
2GC-04-14	G1/4"X19	M14X1.5	8	10	23.5	19	17	
2GC-04-16	G1/4"X19	M16X1.5	10	10	24	19	19	
2GC-06-18	G3/8"X19	M18X1.5	12	11.5	25.5	22	27	
2GC-08-22	G1/2"X14	M22X1.5	15	14	28.5	27	22	
2GC-08-26	G1/2"X14	M26X1.5	18	14	29	27	32	
2GC-12-30	G3/4"X14	M30X2	22	15.5	32	32	36	16 轻系列 L
2GC-16-36	G1"X11	M36X2	28	18	35	41	41	
2GC-20-45	G1.1/4"X11	M45X2	35	20	38	50	50	
2GC-24-52	G1.1/2"X11	M52X2	42	21.5	41.5	55	60	
2GD-04-14	G1/4"X19	M14X1.5	6	10	23	19	17	63 重系列 S
2GD-04-16	G1/4"X19	M16X1.5	8	10	26	19	19	
2GD-06-18	G3/8"X19	M18X1.5	10	11.5	25	22	22	
2GD-06-20	G3/8"X19	M20X1.5	12	11.5	28.5	22	24	
2GD-08-22	G1/2"X14	M22X1.5	14	14	31.5	27	27	
2GD-08-24	G1/2"X14	M24X1.5	16	14	30	27	30	40 重系列 S
2GD-12-30	G3/4"X14	M30X2	20	15.5	36	32	36	
2GD-16-36	G1"X11	M36X2	25	18	38.5	41	46	
2GD-20-42	G1.1/4"X11	M42X2	30	20	42	50	50	
2GD-24-52	G1.1/2"X11	M52X2	38	21.5	47.5	55	60	

31.5重系列S

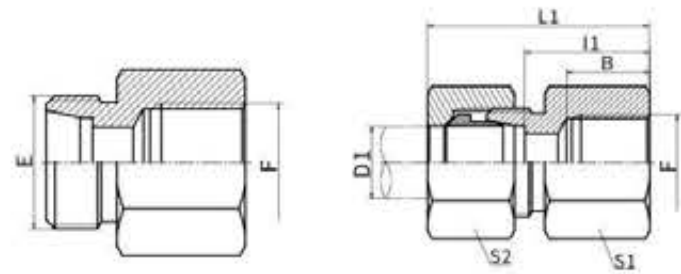
5CB
5DB
5CB-RN
5DB-RN
英管内螺纹
BSP FEMALE

代号 PART NO.	螺纹 THREAD		管子外径 TUBE O.D. D1	尺寸 DIMENSIONS					压力等级 MPa
	E	F		B	I1	L1	S1	S2	
5CB-12-02	M12X1.5	G1/8"X28	6	12	19	34	14	14	31.5 轻系列 L
5CB-12-04	M12X1.5	G1/4"X19	6	16	23	36	19	17	
5CB-14-04	M14X1.5	G1/4"X19	8	17	24	39	19	17	
5CB-14-06	M14X1.5	G3/8"X19	8	17	25	40	24	17	
5CB-14-08	M14X1.5	G1/2"X14	8	20	29	44	27	17	
5CB-16-04	M16X1.5	G1/4"X19	10	17	25	40	19	19	
5CB-16-06	M16X1.5	G3/8"X19	10	17	26	41	24	19	
5CB-16-08	M16X1.5	G1/2"X14	10	20	30	45	27	19	
5CB-18-04	M18X1.5	G1/4"X19	12	17	23	38	19	22	
5CB-18-06	M18X1.5	G3/8"X19	12	17	26	41	24	22	
5CB-18-08	M18X1.5	G1/2"X14	12	20	30	45	27	22	
5CB-22-06	M22X1.5	G3/8"X19	15	17	28	43	24	27	
5CB-22-08	M22X1.5	G1/2"X14	15	20	31	46	27	27	
5CB-26-08	M26X1.5	G1/2"X14	18	20	30.5	47	27	32	
5CB-30-12	M30X2	G3/4"X14	22	22	35.5	52	36	36	16 轻系列 L
5CB-36-16	M36X2	G1"X11	28	24.5	38	55	41	41	
5CB-45-20	M45X2	G1.1/4"X11	35	26.5	41	63	55	50	
5CB-52-24	M52X2	G1.1/2"X11	42	28.5	42.5	65	60	60	
5DB-14-04	M14X1.5	G1/4"X19	6	17	26	41	19	17	63 重系列 S
5DB-16-04	M16X1.5	G1/4"X19	8	17	26	41	19	19	
5DB-18-06	M18X1.5	G3/8"X19	10	17	26.5	43	24	22	
5DB-20-06	M20X1.5	G3/8"X19	12	17	27.5	28	24	24	
5DB-20-08	M20X1.5	G1/2"X14	12	20	30.5	31	24	24	
5DB-22-08	M22X1.5	G1/2"X14	14	20	32	50	30	27	
5DB-24-08	M24X1.5	G1/2"X14	16	20	31.5	50	30	30	40 重系列 S
5DB-30-12	M30X2	G3/4"X14	20	22	34.5	56	36	36	
5DB-36-16	M36X2	G1"X11	25	24.5	37.5	62	41	46	
5DB-42-20	M42X2	G1.1/4"X11	30	26.5	42	69	55	50	
5DB-52-24	M52X2	G1.1/2"X11	38	28.5	43.5	74	60	60	

注：如需带卡套及卡套螺母整套订货，请在代号后加“RN”，如5CB-45-20RN。
 Note: In case if you are interested to order the adapter in complete set with cutting ring and nut, it is necessary to insert suffix "RN" after our part no., for example 5CB-45-20RN.

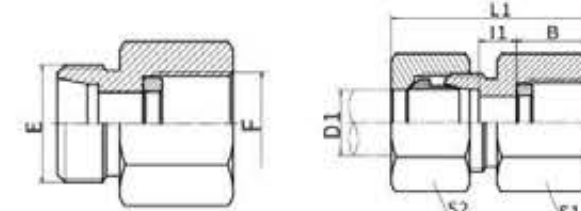

5CB-GDK
5DB-GDK
5CB-GDK/RN
5DB-GDK/RN
钢垫密封英管压力表接头
BSP PRESSURE GAUGE CONNECTOR
WITH DKI SEALING RING

代号 PART NO.	螺纹 THREAD		管子外径 D1 TUBE O.D.	尺寸 DIMENSIONS					密封钢垫 SEALING RING DKI	压力等级 MPa
	E	F		I1	L1	B	S1	S2		
5CB-12-04GDK	M12X1.5	G1/4"X19	6	7.5	37	14.5	19	14	DP-B04DK	31.5 轻系列 L
5CB-14-04GDK	M14X1.5	G1/4"X19	8	7.5	37	14.5	19	17	DP-B04DK	
5CB-16-04GDK	M16X1.5	G1/4"X19	10	8.5	38	14.5	19	19	DP-B04DK	
5CB-18-04GDK	M18X1.5	G1/4"X19	12	8.5	38	14.5	19	22	DP-B04DK	
5DB-14-08GDK	M14X1.5	G1/2"X14	6	11	46	20	27	17	DP-B08DK	63 重系列 S
5DB-16-08GDK	M16X1.5	G1/2"X14	8	11	46	20	27	19	DP-B08DK	
5DB-18-08GDK	M18X1.5	G1/2"X14	10	10.5	47	20	27	22	DP-B08DK	
5DB-20-08GDK	M20X1.5	G1/2"X14	12	10.5	47	20	27	24	DP-B08DK	

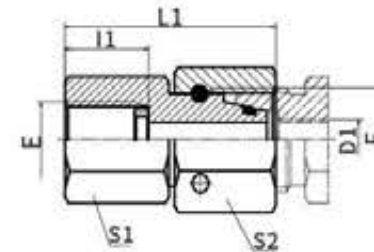
注：如需带卡套及卡套螺母整套订货，请在代号后加“RN”，如5CB-18-04GDK/RN。
 Note: In case if you are interested to order the adapter in complete set with cutting ring and nut, it is necessary to insert suffix "RN" after our part no., for example 5CB-18-04GDK/RN.

7BC-GDK/S
7BD-GDK/S
钢垫密封英管压力表接头
BSP PRESSURE GAUGE CONNECTOR
WITH DKI SEALING RING

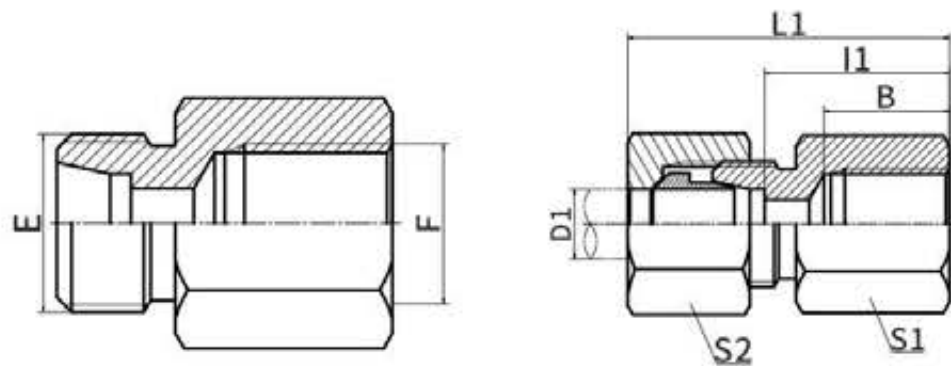
代号 PART NO.	螺纹 THREAD		管子外径 D1 TUBE O.D.	尺寸 DIMENSIONS				密封钢垫 SEALING RING DKI	压力等级 MPa
	E	F		I1	L1	S1	S2		
7BC-04-12GDK/S	G1/4"X19	M12X1.5	6	14.5	35.5	19	14	DP-B04DK	31.5 轻系列 L
7BC-04-14GDK/S	G1/4"X19	M14X1.5	8	14.5	35.5	19	17	DP-B04DK	
7BC-04-16GDK/S	G1/4"X19	M16X1.5	10	14.5	36	19	19	DP-B04DK	
7BC-04-18GDK/S	G1/4"X19	M18X1.5	12	14.5	36	19	22	DP-B04DK	
7BD-04-14GDK/S	G1/4"X19	M14X1.5	6	14.5	35.5	19	17	DP-B04DK	63 重系列 S
7BD-04-16GDK/S	G1/4"X19	M16X1.5	8	14.5	35.5	19	19	DP-B04DK	
7BD-04-18GDK/S	G1/4"X19	M18X1.5	10	14.5	36	19	22	DP-B04DK	
7BD-04-20GDK/S	G1/4"X19	M20X1.5	12	14.5	39	19	24	DP-B04DK	
7BD-08-14GDK/S	G1/2"X14	M14X1.5	6	20	42.5	27	17	DP-B08DK	
7BD-08-16GDK/S	G1/2"X14	M16X1.5	8	20	43	27	19	DP-B08DK	
7BD-08-18GDK/S	G1/2"X14	M18X1.5	10	20	43.5	27	22	DP-B08DK	
7BD-08-20GDK/S	G1/2"X14	M14X1.5	12	20	45	27	24	DP-B08DK	



5CM
5DM

5CM-RN
5DM-RN

公制内螺纹
METRIC FEMALE

代号 PART NO.	螺纹 THREAD		管子外径 TUBE O.D. D1	尺寸 DIMENSIONS					压力等级 MPa
	E	F		B	I1	L1	S1	S2	
5CM-12-10	M12X1.5	M10X1	6	12.5	19.5	34	14	14	25 轻系列 L
5CM-14-12	M14X1.5	M12X1.5	8	17	24	39	17	17	
5CM-16-14	M16X1.5	M14X1.5	10	17	25	40	19	19	
5CM-18-16	M18X1.5	M16X1.5	12	17	26	41	22	22	
5CM-22-18	M22X1.5	M18X1.5	15	17	28	43	24	27	
5CM-26-22	M26X1.5	M22X1.5	18	19	29.5	46	30	32	
5CM-30-26	M30X2	M26X1.5	22	21	34.5	51	32	36	16 轻系列 L
5CM-36-33	M36X2	M33X2	28	24	37.5	54	41	41	
5CM-45-42	M45X2	M42X2	35	26	40.5	62	55	50	
5CM-52-48	M52X2	M48X2	42	28	42	65	60	60	
5DM-14-12	M14X1.5	M12X1.5	6	17	26	41	17	17	63 重系列 S
5DM-16-14	M16X1.5	M14X1.5	8	17	26	41	19	19	
5DM-18-16	M18X1.5	M16X1.5	10	17	26.5	43	22	22	
5DM-20-18	M20X1.5	M18X1.5	12	17	27.5	44	24	24	
5DM-22-20	M22X1.5	M20X1.5	14	19	31	49	27	27	
5DM-24-22	M24X1.5	M22X1.5	16	19	30.5	49	30	30	40 重系列 S
5DM-30-27	M30X2	M27X2	20	22	34.5	56	36	36	
5DM-36-33	M36X2	M33X2	25	24	37	61	41	46	
5DM-42	M42X2	M42X2	30	26	41.5	68	55	50	
5DM-52-48	M52X2	M48X2	38	28	43	74	60	60	31.5重系列S

注：如需带卡套及卡套螺母整套订货，则请在代号后加“RN”，如5DM-30-27RN。
Note: In case if you are interested to order the adapter in complete set with cutting ring and nut, it is necessary to insert suffix "RN" after our part no., for example 5DM-30-27RN.

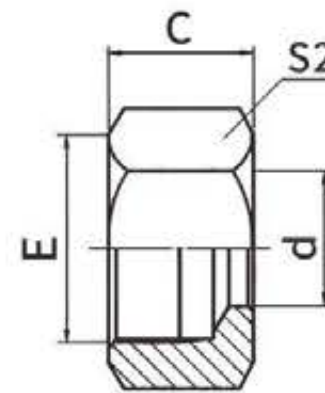

NL
NS

卡套螺母
RETAINING NUTS

代号 PART NO.	螺纹 THREAD E	管子外径 TUBE O.D.	尺寸 DIMENSIONS			压力等级 MPa
			C	d	S2	
NL-08LL	M8X1	4	11	4	10	10 特轻系列 LL
NL-10LL	M10X1	6	11.5	6	12	
NL-12LL	M12X1	8	12	8	14	
NL-12	M12X1.5	6	14.5	6	14	轻系列 L
NL-14	M14X1.5	8	14.5	8	17	
NL-16	M16X1.5	10	15.5	10	19	
NL-18	M18X1.5	12	15.5	12	22	
NL-22	M22X1.5	15	17	15	27	
NL-26	M26X1.5	18	18	18	32	
NL-30	M30X2	22	20	22	36	
NL-36	M36X2	28	21	28	41	
NL-45	M45X2	35	24	35	50	
NL-52	M52X2	42	24	42	60	
NS-14	M14X1.5	6	16.5	6	17	重系列 S
NS-16	M16X1.5	8	16.5	8	19	
NS-18	M18X1.5	10	17.5	10	22	
NS-20	M20X1.5	12	17.5	12	24	
NS-22	M22X1.5	14	20.5	14	27	
NS-24	M24X1.5	16	20.5	16	30	
NS-30	M30X2	20	24	20	36	
NS-36	M36X2	25	27	25	46	
NS-42	M42X2	30	29	30	50	
NS-52	M52X2	38	32.5	38	60	

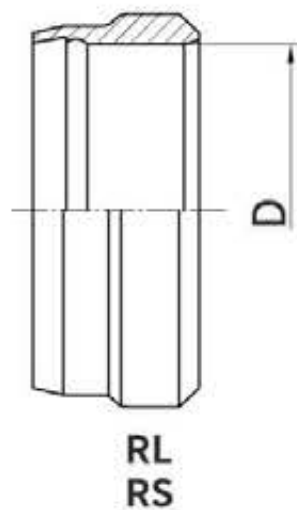

卡套
CUTTING RING

代号 PART NO.	管子外径D TUBE O.D.	尺寸 DIMENSIONS				备注
RL-04LL	4					特轻系列 LL
RL-06LL	6					
RL-08LL	8					
RL-06	6	与重系列相应规格一致				轻系L列
RL-08	8					
RL-10	10					
RL-12	12					
RL-15	15					
RL-22	22					
RL-28	28					重系S列
RL-35	35					
RL-42	42					
RS-06	6					
RS-08	8					
RS-10	10					
RS-12	12					
RS-14	14					
RS-16	16					
RS-20	20					
RS-25	25					
RS-30	30					
RS-38	38					

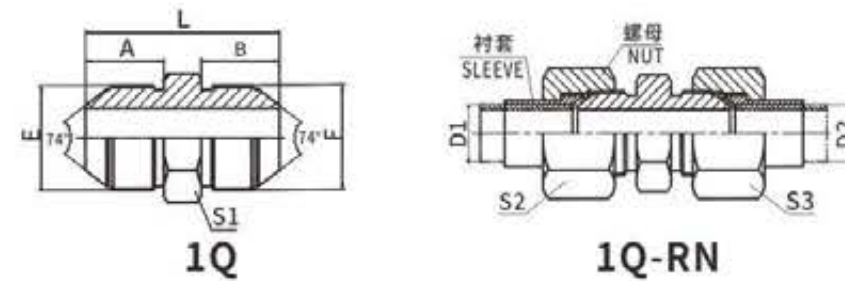

公制外螺纹74° 外锥
METRIC MALE 74° CONE

代号 PART NO.	螺纹 THREAD		管子外径TUBE O.D. D1,D2	尺寸 DIMENSIONS				
	E	F		A	B	L	S1	S2,S3
1Q-10	M10X1	M10X1	5	12	12	30	12	14
1Q-12	M12X1.5	M12X1.5	6	15.7	15.7	37.5	14	14
1Q-14	M14X1.5	M14X1.5	8	17	17	40	17	17
1Q-16	M16X1.5	M16X1.5	10	18	18	42	17	19
1Q-18	M18X1.5	M18X1.5	12	18	18	42	19	22
1Q-24	M24X1.5	M24X1.5	16	20	20	50	27	30
1Q-27	M27X1.5	M27X1.5	18	20	20	50	30	32
1Q-30	M30X1.5	M30X1.5	20	23	23	57	32	36
1Q-30E	M30X2	M30X2	20	26	26	63	32	36
1Q-33	M33X2	M33X2	22	26	26	63	36	38
1Q-36	M36X2	M36X2	25	26	26	63	38	41
1Q-39	M39X2	M39X2	28	26	26	65	41	46
1Q-42	M42X2	M42X2	32	28.5	28.5	70	46	50
1Q-45	M45X2	M45X2	34	28.5	28.5	70	46	55

注:如需带衬套及螺母整套订货, 则请在代号后加“RN”, 如1Q-18RN, 衬套代号NB500-Q, 螺母代号NB200-Q。
Note: In case if you are interested to order the adapter in complete set with sleeve and nut, it is necessary to insert suffix "RN" after our part no., for example 1Q-18RN, The sleeve NO. is NB500-Q and the nut NO. is NB200-Q.

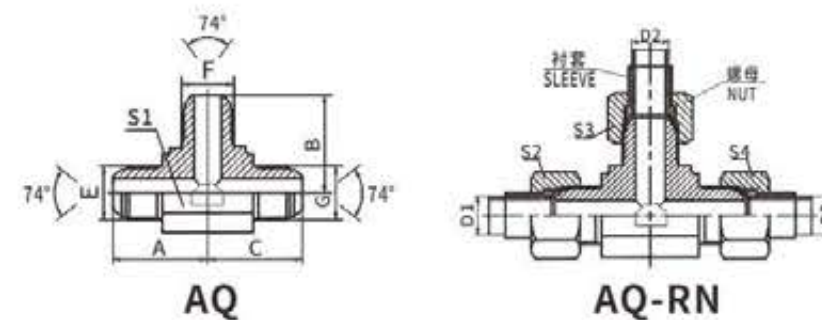

公制外螺纹74° 外锥三通
METRIC MALE 74° CONE TEE

代号 PART NO.	螺纹 THREAD			管子外径TUBE O.D. D1,D2,D3	尺寸 DIMENSIONS				
	E	F	G		A	B	C	S1	S2,S3,S4
AQ-14	M14X1.5	M14X1.5	M14X1.5	8	27	27	27	14	17
AQ-16	M16X1.5	M16X1.5	M16X1.5	10	29.5	29.5	29.5	16	19
AQ-18	M18X1.5	M18X1.5	M18X1.5	12	34	34	34	19	22
AQ-22	M22X1.5	M22X1.5	M22X1.5	14	37.5	37.5	37.5	22	27
AQ-27	M27X1.5	M27X1.5	M27X1.5	18	41.5	41.5	41.5	27	32
AQ-33	M33X2	M33X2	M33X2	22	49.5	49.5	49.5	33	38

注:如需带衬套及螺母整套订货, 则请在代号后加“RN”, 如1Q-18RN, 衬套代号NB500-Q, 螺母代号NB200-Q。
Note: In case if you are interested to order the adapter in complete set with sleeve and nut, it is necessary to insert suffix "RN" after our part no., for example 1Q-18RN, The sleeve NO. is NB500-Q and the nut NO. is NB200-Q.

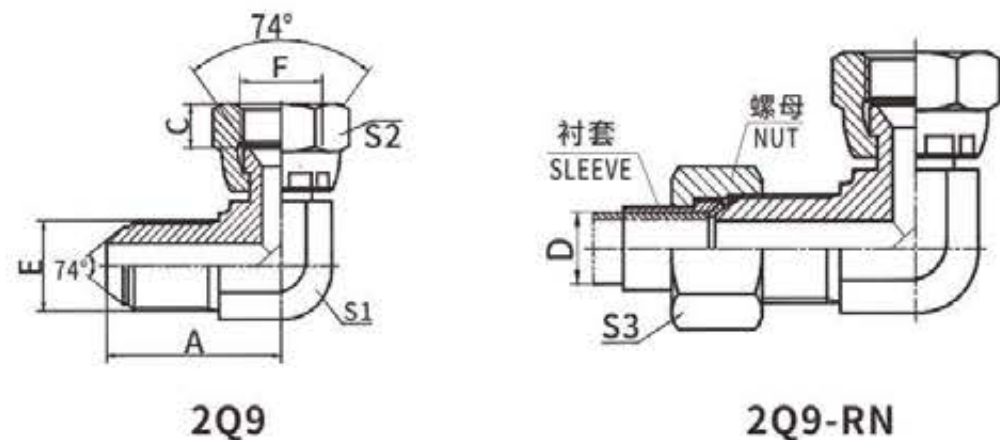

公制外螺纹74°外锥/公制丙螺纹74°内锥
METRIC MALE 74° CONE / METRIC FEMALE 74° SEAT

代号 PART NO.	螺纹 THREAD		管子外径 TUBE O.D. D	尺寸 DIMENSIONS				
	E	F		A	C	S1	S2	S3
2Q9-14	M14X1.5	M14X1.5	8	30.2	8.5	14	19	17
2Q9-16	M16X1.5	M16X1.5	10	32.5	8	16	22	19
2Q9-18	M18X1.5	M18X1.5	12	34	8	19	24	22
2Q9-22	M22X1.5	M22X1.5	14	37.5	10	22	27	27
2Q9-27	M27X1.5	M27X1.5	18	41.5	10	27	32	32
2Q9-33	M33X2	M33X2	22	49.5	13	33	41	38
2Q9-36	M36X2	M36X2	25	51.5	13	36	41	41
2Q9-39	M39X2	M39X2	28	55.5	13	41	46	46
2Q9-45	M45X2	M45X2	34	62.5	15	48	55	55

注:如需带衬套及螺母整套订货, 则请在代号后加“RN”, 如2Q9-18RN, 衬套代号NB500-Q, 螺母代号NB200-Q。
Note: In case if you are interested to order the adapter in complete set with sleeve and nut, it is necessary to insert suffix "RN" after our part no., for example 2Q9-18RN, The sleeve NO. is NB500-Q and the nut NO. is NB200-Q.

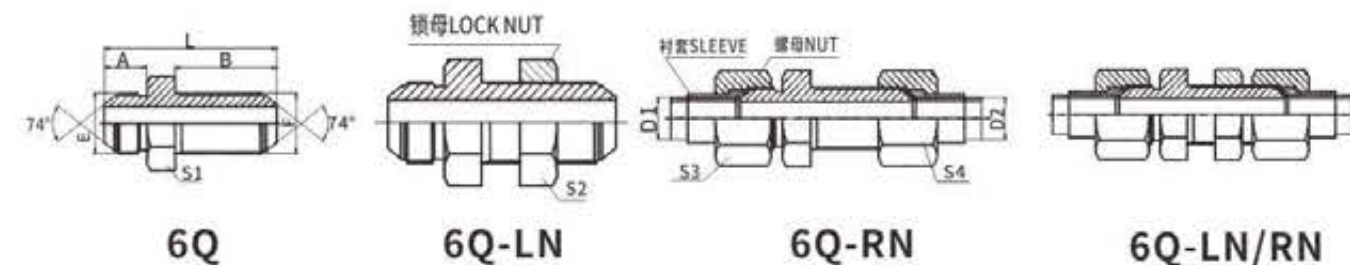

公制外螺纹74°外锥过板接头
METRIC MALE 74° CONE BULKHEAD

代号 PART NO.	螺纹 THREAD		管子外径 TUBE O.D. D1, D2	尺寸 DIMENSIONS					
	E	F		A	B	L	S1	S2	S3, S4
6Q-10	M10X1	M10X1	5	12.5	34	52.5	14	14	14
6Q-12	M12X1.5	M12X1.5	6	15.7	38	59.7	17	17	14
6Q-16	M16X1.5	M16X1.5	10	18	41	65	19	22	19
6Q-18	M18X1.5	M18X1.5	12	18	43	69	24	24	22
6Q-22	M22X1.5	M22X1.5	14	19.5	44	73.5	27	27	27
6Q-24	M24X1.5	M24X1.5	16	20	45	75	27	30	30
6Q-27	M27X1.5	M27X1.5	18	20	48	78	30	32	32
6Q-30	M30X1.5	M30X1.5	20	23	53	87	34	36	36
6Q-33	M33X2	M33X2	22	26	55	92	36	41	38
6Q-36	M36X2	M36X2	25	25	56	94	41	41	41
6Q-39	M39X2	M39X2	28	26	58	97	41	46	46
6Q-42	M42X2	M42X2	32	28.5	59	102.5	50	50	50
6Q-45	M45X2	M45X2	34	28.5	60	103.5	50	50	55

注:如需带锁母订货, 则请在代号后加“LN”, 如6Q-18LN; 如需带衬套及螺母整套订货, 则请在代号后加“RN”, 如6Q-18RN; 如需带锁母、衬套及螺母订货, 在代号后加“LN/RN”, 如6Q-18LNRN; 衬套代号NB500-Q, 螺母代号NB200-Q, 锁母代号8C。
Note: In case if you are interested to order the adapter with lock nut, please insert suffix "LN" after our part no. for example 6Q-18LN; order the adapter with sleeve and nut, please insert suffix "RN" after our part no. for example 6Q-18RN; order the adapter with lock nut and sleeve and nut, insert suffix "LN/RN" after part no. for example 6Q-18LNRN; The sleeve NO. is NB500-Q and the nut NO. is NB200-Q and the lock nut no. is 8C.

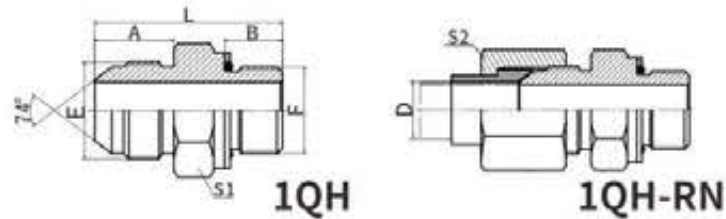
公制74°外锥/公制外螺纹
轻系列ISO 6149-3
METRIC 74° CONE / METRIC MALE
L-SERIES ISO 6149-3

代号 PART NO.	螺纹 THREAD		管子外径D TUBE O.D.	O形圈O-RING F端	尺寸 DIMENSIONS				
	E	F			A	B	L	S1	S2
1QH-14-12	M14X1.5	M12X1.5	8	O09.3X2.4	17	11.0	36.5	17	17
1QH-16-14	M16X1.5	M14X1.5	10	O11.3X2.4	18	11.0	37.5	19	19
1QH-18-16	M18X1.5	M16X1.5	12	O13.3X2.4	18	11.5	38	22	22
1QH-22-18	M22X1.5	M18X1.5	14	O15.3X2.4	19.5	12.5	40.5	24	27
1QH-27-22	M27X1.5	M22X1.5	18	O19.3X2.4	20	13.0	44	27	32
1QH-30-27	M30X1.5	M27X2	20	O23.5X3.0	23	16.0	50	32	36
1QH-33-27	M33X2	M27X2	22	O23.5X3.0	26	16.0	53	34	38
1QH-36-33	M36X2	M33X2	25	O29.5X3.0	26	16.0	55	41	41
1QH-39-33	M39X2	M33X2	28	O29.5X3.0	26	16.0	55	41	46
1QH-45-42	M45X2	M42X2	34	O38.5X3.0	28.5	16.0	59.5	50	55

注: 1 如需带衬套及螺母整套订货, 则请在代号后加“RN”, 如1QH-22-18/RN, 衬套代号NB500-Q, 螺母代号NB200-Q。
 2 F端与ISO 9974-1油口相配, 去掉挡圈则与ISO 6149-1油口相配。Note: 1 In case if you are interested to order the adapter in complete set with sleeve and nut, it is necessary to insert suffix “RN” after our part NO., for example 1QH-22-18/RN, The sleeve NO. is NB500-Q and the nut NO. is NB200-Q. 2 F end is connected with ISO 9974-1 port and connected with ISO 6149-1 port without retaining ring.

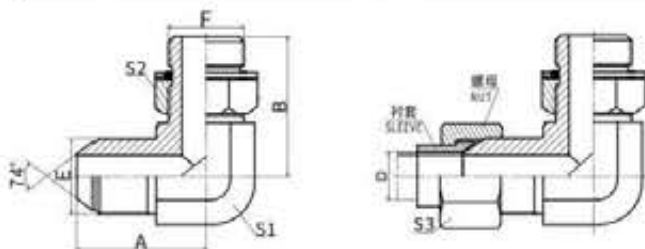
90°弯公制74°外锥/公制外螺纹
可调向柱端轻系列ISO 6149-3
90° ELBOW METRIC 74° CONE / METRIC MALE
ADJUSTABLE STUD END L-SERIES ISO 6149-3
1QH9-OG **1QH9-OG/RN**

代号 PART NO.	螺纹 THREAD		管子外径D TUBE O.D.	O形圈O-RING F端	尺寸 DIMENSIONS				
	E	F			A	B	S1	S2	S3
1QH9-14-12OG	M14X1.5	M12X1.5	8	O09.3X2.4	30.2	32	14	17	17
1QH9-16-14OG	M16X1.5	M14X1.5	10	O11.3X2.4	32	35.5	16	19	19
1QH9-18-16OG	M18X1.5	M16X1.5	12	O13.3X2.4	34	36	19	22	22
1QH9-22-18OG	M22X1.5	M18X1.5	14	O15.3X2.4	37.5	39.5	22	24	27
1QH9-27-22OG	M27X1.5	M22X1.5	18	O19.3X2.4	41.5	43.5	27	27	32
1QH9-30-27OG	M30X1.5	M27X2	20	O23.5X3.0	45.8	50	30	32	36
1QH9-33-27OG	M33X2	M27X2	22	O23.5X3.0	49.5	52	33	32	41
1QH9-36-33OG	M36X2	M33X2	25	O29.5X3.0	51.5	54	36	41	41
1QH9-39-33OG	M39X2	M33X2	28	O29.5X3.0	55.5	57.2	41	41	46
1QH9-45-42OG	M45X2	M42X2	34	O38.5X3.0	62.5	61	48	50	50

注: 1 如需带衬套及螺母整套订货, 则请在代号后加“RN”, 如1QH9-22-18/RN, 衬套代号NB500-Q, 螺母代号NB200-Q。
 2 F端与ISO 9974-1油口相配, 去掉挡圈则与ISO 6149-1油口相配。Note: 1 In case if you are interested to order the adapter in complete set with sleeve and nut, it is necessary to insert suffix “RN” after our part NO., for example 1QH9-22-18/RN, The sleeve NO. is NB500-Q and the nut NO. is NB200-Q. 2 F end is connected with ISO 9974-1 port and connected with ISO 6149-1 port without retaining ring.

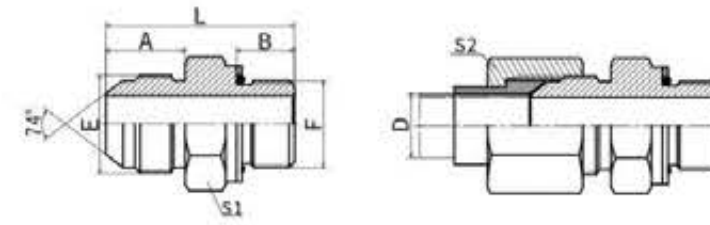
公制外螺纹74°外锥/英管外螺纹O形圈
METRIC MALE 74° CONE /
BSP MALE O-RING
1QG **1QG-RN**

代号 PART NO.	螺纹 THREAD		管子外径D TUBE O.D.	O形圈O-RING F端	尺寸 DIMENSIONS				
	E	F			A	B	L	S1	S2
1QG-14-04	M14X1.5	G1/4"X19	8	O111	17	11	36	19	17
1QG-16-06	M16X1.5	G3/8"X19	10	O113	18	11.5	40	22	19
1QG-18-06	M18X1.5	G3/8"X19	12	O113	18	11.5	40	22	22
1QG-18-08	M18X1.5	G1/2"X14	12	O115	18	14	43	27	22
1QG-22-08	M22X1.5	G1/2"X14	14	O115	19.5	14	44.5	27	27
1QG-27-12	M27X1.5	G3/4"X14	18	O119	20	15.5	49.5	32	32
1QG-30-12	M30X1.5	G3/4"X14	20	O119	23	15.5	52.5	32	36
1QG-39-16	M39X2	G1"X11	28	O217	26	18	60	41	46
1QG-45-20	M45X2	G1.1/4"X11	34	O222	28.5	20	66.5	50	55

注: 1 如需带衬套及螺母整套订货, 则请在代号后加“RN”, 如1QG-18-06RN, 衬套代号NB500-Q, 螺母代号NB200-Q。
 2 F端与DIN 3852油口相配。Note: 1 In case if you are interested to order the adapter in complete set with sleeve and nut, it is necessary to insert suffix “RN” after our part NO., for example 1QG-18-06RN, The sleeve NO. is NB500-Q and the nut NO. is NB200-Q. 2 F end is connected with DIN 3852 port.

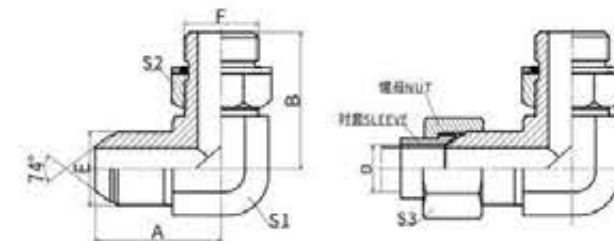

90°弯公制外螺纹74°外锥/
英管外螺纹O形圈可调向柱端
90° ELBOW METRIC MALE 74° CONE /
BSP MALE O-RING ADJUSTABLE STUD END
1QG9-OG **1QG9-OG/RN**

代号 PART NO.	螺纹 THREAD		管子外径D TUBE O.D.	O形圈O-RING F端	尺寸 DIMENSIONS				
	E	F			A	B	S1	S2	S3
1QG9-14-04OG	M14X1.5	G1/4"X19	8	O111	29	31.3	14	19	17
1QG9-16-06OG	M16X1.5	G3/8"X19	10	O113	33	35.8	16	22	19
1QG9-18-06OG	M18X1.5	G3/8"X19	12	O113	34	36.8	19	22	22
1QG9-18-08OG	M18X1.5	G1/2"X14	12	O115	36	43.2	22	27	22
1QG9-22-08OG	M22X1.5	G1/2"X14	14	O115	37.8	43.2	22	27	27
1QG9-27-12OG	M27X1.5	G3/4"X14	18	O119	41.5	49.3	27	32	32
1QG9-30-12OG	M30X1.5	G3/4"X14	20	O119	45.8	52	30	32	36
1QG9-39-16OG	M39X2	G1"X11	28	O217	55.5	58	41	41	46
1QG9-45-20OG	M45X2	G1.1/4"X11	34	O222	62.5	63	48	50	55

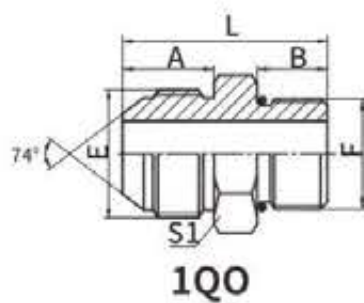
注: 1 如需带衬套及螺母整套订货, 则请在代号后加“RN”, 如1QG9-22-08OG/RN, 衬套代号NB500-Q, 螺母代号NB200-Q。
 2 F端与DIN 3852油口相配。Note: 1 In case if you are interested to order the adapter in complete set with sleeve and nut, it is necessary to insert suffix “RN” after our part NO., for example 1QG9-22-08OG/RN, The sleeve NO. is NB500-Q and the nut NO. is NB200-Q. 2 F end is connected with DIN 3852 port.

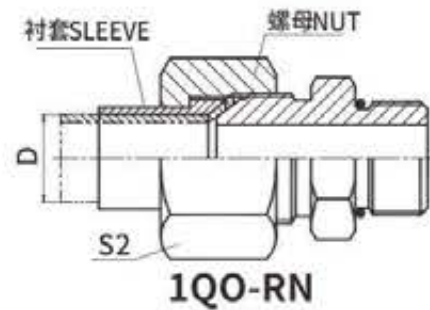

1QO



1QO-RN

公制外螺纹74° 外锥/SAE外螺纹带O形圈轻系列ISO 11926-3
METRIC MALE 74° CONE /SAE O-RING BOSS L-SERIES ISO 11926-3

代号 PART NO.	螺纹 THREAD		管子外径D TUBE O.D.	O形圈O-RING F端	尺寸 DIMENSIONS				
	E	F			A	B	L	S1	S2
1QO-16-06	M16X1.5	9/16"X18	10	O906	18	9.9	35	17	19
1QO-18-08	M18X1.5	3/4"X16	12	O908	18	11.1	37	22	22
1QO-22-10	M22X1.5	7/8"X14	14	O910	19.5	12.7	42	27	27
1QO-27-12	M27X1.5	1.1/16"X12	18	O912	20	15.1	46	32	32
1QO-30-12	M30X1.5	1.1/16"X12	20	O912	23	15.1	49	32	36
1QO-33-16	M33X2	1.5/16"X12	22	O916	26	15.1	54	38	38
1QO-39-16	M39X2	1.5/16"X12	28	O916	26	15.1	58	41	46
1QO-42-20	M42X2	1.5/8"X12	32	O920	28.5	15.1	58	50	50

注:如需带衬套及螺母整套订货, 则请在代号后加 "RN", 如1QO-22-10RN, 衬套代号NB500-Q, 螺母代号NB200-Q。
Note: In case if you are interested to order the adapter in complete set with sleeve and nut, it is necessary to insert suffix "RN" after our part no. for example 1QO-22-10RN, The sleeve NO. is NB500-Q and the nut NO. is NB200-Q.



1QO9-OG

1QO9-OG/RN

90° 弯公制外螺纹74°外锥/SAE外螺纹带O形圈
轻系列ISO 11926-3

90° ELBOW METRIC MALE 74° CONE/
SAE O-RING BOSS L-SERIES ISO 11926-3

代号 PART NO.	螺纹 THREAD		管子外径D TUBE O.D.	O形圈O-RING F端	尺寸 DIMENSIONS				
	E	F			A	B	S1	S2	S3
1QO9-16-06	M16X1.5	9/16"X18	10	O906	32	31.8	16	19	19
1QO9-18-08	M18X1.5	3/4"X16	12	O908	34	36.8	19	24	22
1QO9-22-10	M22X1.5	7/8"X14	14	O910	37.5	44	22	27	27
1QO9-27-12	M27X1.5	1.1/16"X14	18	O912	41.5	51	27	32	32
1QO9-30-12	M30X1.5	1.1/2"X12	20	O912	45.8	53	30	32	38
1QO9-33-16	M33X2	1.5/16"X12	22	O916	51	54.5	33	41	38
1QO9-36-16	M39X2	1.5/16"X12	28	O916	55.5	59.5	41	41	46
1QO9-42-20	M42X2	1.5/8"X12	32	O920	58.5	59	41	50	50

注:1 如需带衬套及螺母整套订货, 则请在代号后加RN, 如1QO9-22-10RN, 衬套代号NB500-Q, 螺母代号NB200-Q。2F端与ISO 11926-1油口相配。

Note: In case if you are interested to order the adapter in complete set with sleeve and nut, it is necessary to insert suffix "RN" after our part no. for example 1QO9-22-10RN, The sleeve NO. is NB500-Q and the nut NO. is NB200-Q.

2 Fend is connected with ISO 11926-1 port.

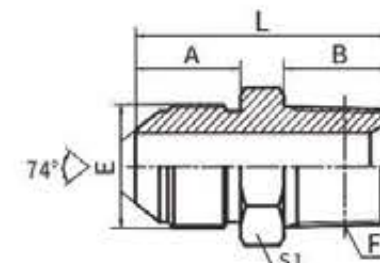

1QN

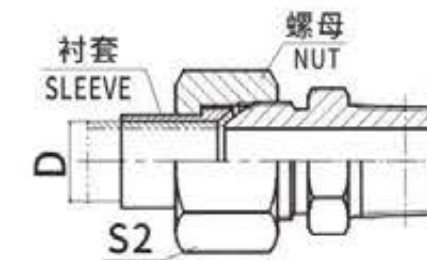

1QN-RN

公制外螺纹74° 外锥/布锥管外螺纹
METRIC MALE 74° CONE/NPT MALE

代号 PART NO.	螺纹 THREAD		管子外径 TUBE O.D. D	尺寸 DIMENSIONS				
	E	F		A	B	L	S1	S2
1QN-12-02	M12X1.5	Z1/8"X27	6	15.7	10.5	32	14	14
1QN-12-04	M12X1.5	Z1/4"X18	6	15.7	15	36.5	14	14
1QN-14-02	M14X1.5	Z1/8"X27	8	17	10.5	33	17	17
1QN-14-04	M14X1.5	Z1/4"X18	8	17	15	38	17	17
1QN-16-04	M16X1.5	Z1/4"X18	10	18	15	39	17	19
1QN-18-04	M18X1.5	Z1/4"X18	12	18	15	39	19	22
1QN-18-06	M18X1.5	Z3/8"X18	12	18	16	40	19	22
1QN-18-08	M18X1.5	Z1/2"X14	12	18	19.5	45.5	22	22
1QN-22-06	M22X1.5	Z3/8"X18	14	19.5	16	43.5	24	27
1QN-22-08	M22X1.5	Z1/2"X14	14	19.5	19.5	47	24	27
1QN-27-06	M27X1.5	Z3/8"X18	18	20	16.5	46	30	32
1QN-27-08	M27X1.5	Z1/2"X14	18	20	19.5	49.5	30	32
1QN-27-12	M27X1.5	Z3/4"X14	18	20	19.5	49.5	30	32
1QN-27-16	M27X1.5	Z1"X11.5	18	20	25.5	56.5	36	32
1QN-30-12	M30X1.5	Z3/4"X14	20	23	19.5	53.5	32	36
1QN-33-12	M33X2	Z3/4"X14	22	26	19.5	56.5	36	38
1QN-36-16	M36X2	Z1"X11.5	25	26	25.5	63	41	41
1QN-39-16	M39X2	Z1"X11.5	28	26	25.5	64.5	41	46
1QN-45-16	M45X2	Z1"X11.5	34	28.5	25.5	67	46	55
1QN-45-20	M45X2	Z1.1/4"X11.5	34	28.5	26.5	68	46	55
1QN-45-24	M45X2	Z1.1/2"X11.5	34	28.5	27.5	71	50	55
1QN-52-20	M52X2	Z1.1/4"X11.5	42	30	26.5	71.5	55	60

注:如需带衬套及螺母整套订货, 则请在代号后加 "RN", 如1QN-22-08RN, 衬套代号NB500-Q, 螺母代号NB200-Q。

Note: In case if you are interested to order the adapter in complete set with sleeve and nut, it is necessary to insert suffix "RN" after our part no., for example 1QN-22-08RN, The sleeve NO. is NB500-Q and the nut NO. is NB200-Q.

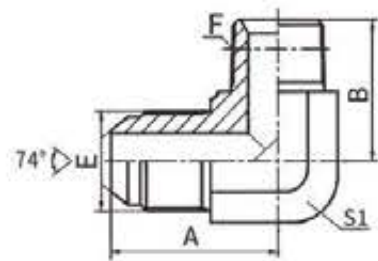

1QN9

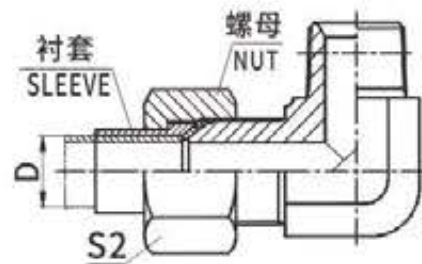

1QN9-RN

90°弯公制外螺纹74°外锥/布锥管外螺纹
90° ELBOW METRIC MALE 74° CONE / NPT MALE

代号 PART NO.	螺纹 THREAD		管子外径 TUBE O.D. D	尺寸 DIMENSIONS			
	E	F		A	B	S1	S2
1QN9-12-02	M12X1.5	Z1/8"X27	6	25.5	21	11	14
1QN9-12-04	M12X1.5	Z1/4"X18	6	28	25.5	14	14
1QN9-14-02	M14X1.5	Z1/8"X27	8	30.2	23.5	14	17
1QN9-14-04	M14X1.5	Z1/4"X18	8	30.2	25.5	14	17
1QN9-16-04	M16X1.5	Z1/4"X18	10	32	26.5	16	19
1QN9-16-08	M16X1.5	Z1/2"X14	10	36	36.7	22	19
1QN9-18-04	M18X1.5	Z1/4"X18	12	34	28.7	19	22
1QN9-18-06	M18X1.5	Z3/8"X18	12	34	31	19	22
1QN9-22-06	M22X1.5	Z3/8"X18	14	37.5	32.5	22	27
1QN9-22-08	M22X1.5	Z1/2"X14	14	37.5	36.7	22	27
1QN9-27-08	M27X1.5	Z1/2"X14	18	41.5	40	27	32
1QN9-27-12	M27X1.5	Z3/4"X14	18	41.5	44	27	32
1QN9-27-16	M27X1.5	Z1"X11.5	18	45	49	33	32
1QN9-30-12	M30X1.5	Z3/4"X14	20	45.8	45	30	36
1QN9-36-16	M36X2	Z1"X11.5	25	51.5	51.5	36	41
1QN9-39-16	M39X2	Z1"X11.5	28	55.5	54.5	41	46
1QN9-42-20	M42X2	Z1.1/4"X11.5	32	57	54.5	41	50
1QN9-45-16	M45X2	Z1"X11.5	34	62.5	58.5	48	55
1QN9-45-20	M45X2	Z1.1/4"X11.5	34	62.5	58.5	48	55
1QN9-45-24	M45X2	Z1.1/2"X11.5	34	62.5	63	48	55

注:如需带衬套及螺母整套订货, 则请在代号后加“RN”, 如1QN9-22-08RN, 衬套代号NB500-Q, 螺母代号NB200-Q。
Note: In case if you are interested to order the adapter in complete set with sleeve and nut, it is necessary to insert suffix "RN" after our part no., for example 1QN9-22-08RN, The sleeve NO. is NB500-Q and the nut NO. is NB200-Q.

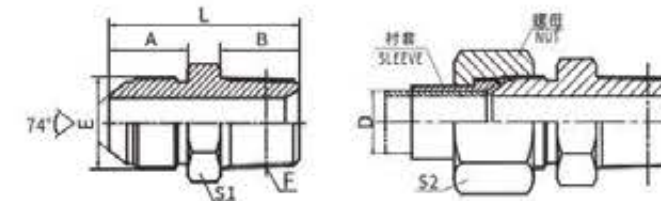

1QT-SP

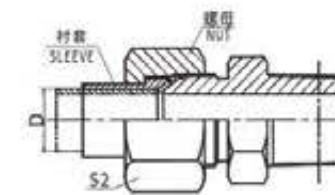

1QT-SP/RN

公制外螺纹74°外锥/英锥管外螺纹
METRIC MALE 74° CONE / BSPT MALE

代号 PART NO.	螺纹 THREAD		管子外径 TUBE O.D. D	尺寸 DIMENSIONS				
	E	F		A	B	L	S1	S2
1QT-10-02SP	M10X1	R1/8"X28	5	12	10	28	12	14
1QT-14-04SP	M14X1.5	R1/4"X19	8	17	14.5	37.5	17	17
1QT-14-06SP	M14X1.5	R3/8"X19	8	17	15	38	17	17
1QT-16-04SP	M16X1.5	R1/4"X19	10	18	14.5	38.5	17	19
1QT-16-06SP	M16X1.5	R3/8"X19	10	18	15	39	17	19
1QT-18-06SP	M18X1.5	R3/8"X19	12	18	15	39	19	22
1QT-22-08SP	M22X1.5	R1/2"X14	14	19.5	20	47.5	24	27
1QT-27-08SP	M27X1.5	R1/2"X14	18	20	20	50	30	32
1QT-27-12SP	M27X1.5	R3/4"X14	18	20	20	50	30	32
1QT-30-12SP	M30X1.5	R3/4"X14	20	23	20	54	32	36
1QT-33-12SP	M33X2	R3/4"X14	22	26	20	57	36	38
1QT-36-16SP	M36X2	R1"X11	25	26	25.5	61.5	38	41
1QT-39-16SP	M39X2	R1"X11	28	26	25.5	64.5	41	46
1QT-45-20SP	M45X2	R1.1/4"X11	34	28.5	26.5	68	46	55

注:如需带衬套及螺母整套订货, 则请在代号后加“RN”, 如1QT-22-08SP/RN, 衬套代号NB500-Q, 螺母代号NB200-Q。
Note: In case if you are interested to order the adapter in complete set with sleeve and nut, it is necessary to insert suffix "RN" after our part no., for example 1QT-22-08SP/RN, The sleeve NO. is NB500-Q and the nut NO. is NB200-Q.

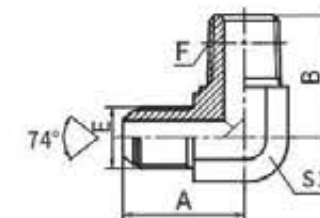

1QT9-SP

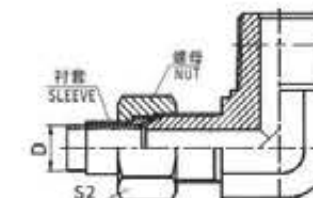

1QT9-SP/RN

90°弯公制外螺纹74°外锥/
英锥管外螺纹
90° ELBOW METRIC MALE 74°
CONE / BSPT MALE

代号 PART NO.	螺纹 THREAD		管子外径 TUBE O.D. D	尺寸 DIMENSIONS			
	E	F		A	B	S1	S2
1QT9-14-04SP	M14X1.5	R1/4"X19	8	30.2	25.5	14	17
1QT9-16-04SP	M16X1.5	R1/4"X19	10	32	26.5	16	19
1QT9-18-06SP	M18X1.5	R3/8"X19	12	34	29	19	22
1QT9-18-08SP	M18X1.5	R1/2"X14	12	36	36	22	22
1QT9-22-08SP	M22X1.5	R1/2"X14	14	37.5	36	22	27
1QT9-27-12SP	M27X1.5	R3/4"X14	18	41.5	44	27	32
1QT9-30-12SP	M30X1.5	R3/4"X14	20	45.8	45.5	30	36
1QT9-33-12SP	M33X2	R3/4"X14	22	49.5	47.5	33	38
1QT9-36-16SP	M36X2	R1"X11	25	51.5	52	36	41
1QT9-39-16SP	M39X2	R1"X11	28	55.5	55.2	41	46
1QT9-45-20SP	M45X2	R1.1/4"X11	34	62.5	61	48	55

注:如需带衬套及螺母整套订货, 则请在代号后加“RN”, 如1QT9-22-08SP/RN, 衬套代号NB500-Q, 螺母代号NB200-Q。
Note: In case if you are interested to order the adapter in complete set with sleeve and nut, it is necessary to insert suffix "RN" after our part no., for example 1QT9-22-08SP/RN, The sleeve NO. is NB500-Q and the nut NO. is NB200-Q.

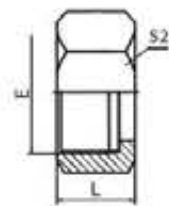
NB200-Q

公制74°锥扩口式管接头螺母GB/T 5647
 METRIC 74° CONE FLARED NUT GB/T 5647

代号 PART NO.	螺纹 THREAD	管子外径 TUBE O.D.	尺寸 DIMENSIONS	
	E	mm	L	S2
NB200-10Q	M10X1	5	13.5	14
NB200-12Q	M12X1.5	6	16.5	14
NB200-14Q	M14X1.5	8	18.5	17
NB200-16Q	M16X1.5	10	19.5	19
NB200-22Q	M22x1.5	14	19.5	27
NB200-24Q	M24X1.5	16	20	30
NB200-27Q	M27X1.5	18	20	32
NB200-30Q	M30X1.5	20	24.5	36
NB200-30EQ	M30X2	20	24.5	36
NB200-33Q	M33X2	22	25.5	38
NB200-36Q	M36X2	25	26	41
NB200-39Q	M39X2	28	27.5	46
NB200-42Q	M42X2	32	28.5	50
NB200-45Q	M45X2	34	29	55

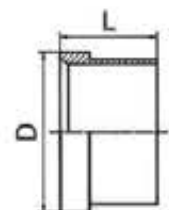
NB500-Q

公制74°锥扩口式管接头衬套GB/T5646
 METRIC 74° CONE FLARED SLEEVE GB/T 5646

代号 PART NO.	管子外径 TUBE O.D.	尺寸 DIMENSIONS		配用螺母 NUT
		D	L	
NB500-05Q	5	8.7	10	NB200-10Q
NB500-06Q	6	10.3	11	NB200-12Q
NB500-08Q	8	12.1	12	NB200-14Q
NB500-10Q	10	14.1	13	NB200-16Q
NB500-14Q	14	20.1	15	NB200-22Q
NB500-16Q	16	22.1	16	NB200-24Q
NB500-18Q	18	25.1	17	NB200-27Q
NB500-20Q	20	28.1	18	NB200-30Q、NB200-30EQ
NB500-22Q	22	30.5	20	NB200-33Q
NB500-25Q	25	33.5	20	NB200-36Q
NB500-28Q	28	36.5	22	NB200-39Q
NB500-32Q	32	39.5	23	NB200-42Q
NB500-34Q	34	42.5	23	NB200-45Q

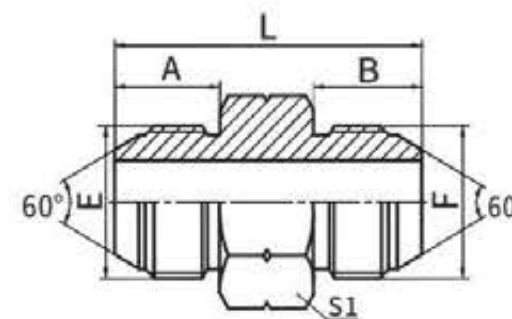
1S

日本英管外螺纹60°外锥
 JIS GAS MALE 60° CONE

代号 PART NO.	螺纹 THREAD		尺寸 DIMENSIONS			
	E	F	A	B	L	S1
1S-02	G1/8"X28	G1/8"X28	12	12	30	14
1S-04	G1/4"X19	G1/4"X19	16	16	38	17
1S-06	G3/8"X19	G3/8"X19	18	18	42	19
1S-08	G1/2"X14	G1/2"X14	20	20	48	22
1S-12	G3/4"X14	G3/4"X14	22	22	54	30
1S-16	G1"X11	G1"X11	24	24	59	36
1S-20	G1.1/4"X11	G1.1/4"X11	27	27	67	46
1S-24	G1.1/2"X11	G1.1/2"X11	27	27	69	50
1S-32	G2"X11	G2"X11	30	30	77	65

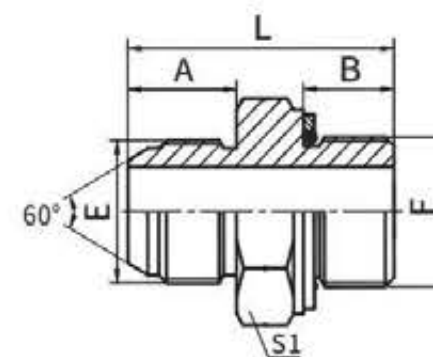
1SG

日本英管外螺纹60°外锥/英管外螺纹O形圈
 JIS GAS MALE 60° CONE/ BSPP MALE O-RING

代号 PART NO.	螺纹 THREAD		O形圈 O-RING F端	尺寸 DIMENSIONS			
	E	F		A	B	L	S1
1SG-02	G1/8"X28	G1/8"X28	O011	12	9.5	29	14
1SG-04	G1/4"X19	G1/4"X19	O111	16	11	33.5	19
1SG-06	G3/8"X19	G3/8"X19	O113	18	11.5	37.5	22
1SG-08	G1/2"X14	G1/2"X14	O115	20	14	44	27
1SG-12	G3/4"X14	G3/4"X14	O119	22	15.5	48.5	32
1SG-16	G1"X11	G1"X11	O217	24	18	55	41
1SG-20	G1.1/4"X11	G1.1/4"X11	O222	27	20	59	50
1SG-24	G1.1/2"X11	G1.1/2"X11	O224	27	21.5	62.5	55

注: F端与DIN3852油口相配。 F end is connected with DIN 3852 port.

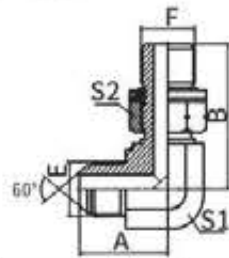
1SG9-OG

90° 弯日本英管外螺纹60° 外锥/

英管外螺纹O形圈可调向柱端

90° ELBOW JIS GAS MALE 60° CONE/

BSPP MALE O-RING ADJUSTABLE STUD END

代号 PART NO.	螺纹 THREAD		O形圈O-RING F端	尺寸 DIMENSIONS			
	E	F		A	B	S1	S2
1SG9-02OG	G1/8"X28	G1/8"X28	O011	21.8	26.2	11	14
1SG9-04OG	G1/4"X19	G1/4"X19	O111	28	31.3	14	19
1SG9-06OG	G3/8"X19	G3/8"X19	O113	29	35.8	16	22
1SG9-08OG	G1/2"X14	G1/2"X14	O115	38	43.2	22	27
1SG9-12OG	G3/4"X14	G3/4"X14	O119	43	49.3	27	32
1SG9-16OG	G1"X11	G1"X11	O217	48.5	53	33	41
1SG9-20OG	G1.1/4"X11	G1.1/4"X11	O222	57	59	41	50
1SG9-24OG	G1.1/2"X11	G1.1/2"X11	O224	61	65	48	55

注: F端与DIN3852油口相配。 F end is connected with DIN 3852 port.

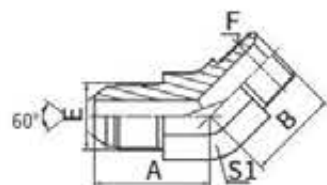
1ST4-SP

45° 弯日本英管外螺纹60°外锥, 英锥管外螺纹

45° ELBOW JIS GAS MALE 60° CONE/ BSPT MALE

代号 PART NO.	螺纹 THREAD		尺寸 DIMENSIONS			
	E	F	A	B	S1	
1ST4-02SP	G1/8"X28	R1/8"X28	19	17	11	
1ST4-02-04SP	G1/8"X28	R1/4"X19	19.8	21	14	
1ST4-04SP	G1/4"X19	R1/4"X19	24	21	14	
1ST4-04-02SP	G1/4"X19	R1/8"X28	24.5	17.5	14	
1ST4-04-06SP	G1/4"X19	R3/8"X19	24.5	23	16	
1ST4-04-08SP	G1/4"X19	R1/2"X14	26.5	29.5	22	
1ST4-06SP	G3/8"X19	R3/8"X19	26	23	16	
1ST4-06-04SP	G3/8"X19	R1/4"X19	26	21	16	
1ST4-06-08SP	G3/8"X19	R1/2"X14	28.5	29.5	22	
1ST4-08SP	G1/2"X14	R1/2"X14	31	29.5	22	
1ST4-08-06SP	G1/2"X14	R3/8"X19	30.5	25	22	
1ST4-12SP	G3/4"X14	R3/4"X14	34.5	30.5	27	
1ST4-12-08SP	G3/4"X14	R1/2"X14	34	30	27	
1ST4-16SP	G1"X11	R1"X11	37.5	38	33	
1ST4-16-12SP	G1"X11	R3/4"X14	37.5	32	33	
1ST4-20SP	G1.1/4"X11	R1.1/4"X11	44.5	43	41	
1ST4-24SP	G1.1/2"X11	R1.1/2"X11	47.5	47	48	
1ST4-32SP	G2"X11	R2"X11	54	53	63	

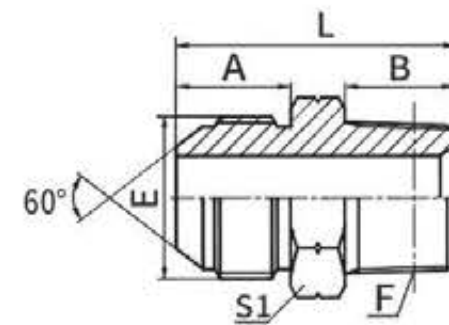
1ST-SP

日本英管外螺纹60° 外锥/英锥管外螺纹

JIS GAS MALE 60° CONE/ BSPT MALE

代号 PART NO.	螺纹 THREAD		尺寸 DIMENSIONS			
	E	F	A	B	L	S1
1ST-02SP	G1/8"X28	R1/8"X28	12	10	28	14
1ST-02-04SP	G1/8"X28	R1/4"X19	12	14.5	32.5	17
1ST-04SP	G1/4"X19	R1/4"X19	16	14.5	36.5	17
1ST-04-02SP	G1/4"X19	R1/8"X28	16	10	32	17
1ST-04-06SP	G1/4"X19	R3/8"X19	16	15	37	19
1ST-04-08SP	G1/4"X19	R1/2"X14	16	20	44	22
1ST-06-04SP	G3/8"X19	R1/4"X19	18	14.5	40.5	22
1ST-06-08SP	G3/8"X19	R1/2"X14	18	20	46	22
1ST-08SP	G1/2"X14	R1/2"X14	20	20	48	22
1ST-08-04SP	G1/2"X14	R1/4"X19	20	14.5	42.5	22
1ST-08-06SP	G1/2"X14	R3/8"X19	20	15	45	27
1ST-08-12SP	G1/2"X14	R3/4"X14	20	20	50	27
1ST-12SP	G3/4"X14	R3/4"X14	22	20	53	30
1ST-12-08SP	G3/4"X14	R1/2"X14	22	20	52	30
1ST-12-16SP	G3/4"X14	R1"X11	22	25.5	58.5	36
1ST-16SP	G1"X11	R1"X11	24	25.5	62.5	41
1ST-16-12SP	G1"X11	R3/4"X14	24	20	57	41
1ST-20SP	G1.1/4"X11	R1.1/4"X11	27	26.5	66	46
1ST-24SP	G1.1/2"X11	R1.1/2"X11	27	26.5	67.5	50
1ST-32SP	G2"X11	R2"X11	30	30	77	65

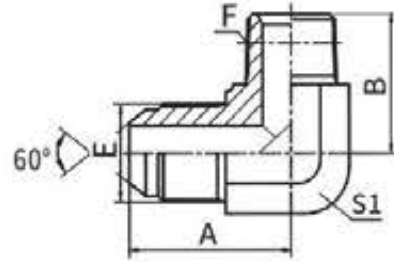

1ST9-SP

90° 弯日本英管外螺纹60°外锥/英锥管外螺纹
90° ELBOW JIS GAS MALE 60°CONE /BSPT MALE

代号 PART NO.	螺纹 THREAD		尺寸 DIMENSIONS		
	E	F	A	B	S1
1ST9-02SP	G1/8"X28	R1/8"X28	21.8	21	11
1ST9-02-04SP	G1/8"X28	R1/4"X19	24.3	25.5	14
1ST9-04SP	G1/4"X19	R1/4"X19	29	25.5	14
1ST9-04-02SP	G1/4"X19	R1/8"X28	29	23.5	14
1ST9-04-06SP	G1/4"X19	R3/8"X19	30	28.5	16
1ST9-06-04SP	G3/8"X19	R1/4"X19	31.5	26.5	16
1ST9-06-08SP	G3/8"X19	R1/2"X14	36	36	22
1ST9-08SP	G1/2"X14	R1/2"X14	38	36	22
1ST9-08-06SP	G1/2"X14	R3/8"X19	38	32.5	22
1ST9-08-12SP	G1/2"X14	R3/4"X14	41	43.5	27
1ST9-12SP	G3/4"X14	R3/4"X14	43	43.5	27
1ST9-12-08SP	G3/4"X14	R1/2"X14	43	39.5	27
1ST9-12-16SP	G3/4"X14	R1"X11	47	50	33
1ST9-16SP	G1"X11	R1"X11	48.5	50	33
1ST9-20SP	G1.1/4"X11	R1.1/4"X11	57	56.5	41
1ST9-24SP	G1.1/2"X11	R1.1/2"X11	61	62.5	48
1ST9-32SP	G2"X11	R2"X11	73.2	74.2	63

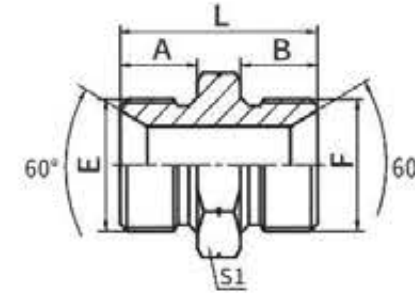

1B

英管外螺纹60° 内锥或六角端面用组合垫密封
BSPP MALE DOUBLE USE FOR 60° SEAT
OR BONDED SEAL

代号 PART NO.	螺纹 THREAD		尺寸 DIMENSIONS			
	E	F	A	B	L	S1
1B-02	G1/8"X28	G1/8"X28	10	10	26	14
1B-02-04	G1/8"X28	G1/4"X19	10	12	28	19
1B-02-06	G1/8"X28	G3/8"X19	10	13.5	31.5	22
1B-02-08	G1/8"X28	G1/2"X14	10	16	36	27
1B-04	G1/4"X19	G1/4"X19	12	12	30	19
1B-04-08	G1/4"X19	G1/2"X14	12	16	38	27
1B-04-10	G1/4"X19	G5/8"X14	12	17.5	39.5	30
1B-06	G3/8"X19	G3/8"X19	13.5	13.5	33	22
1B-06-08	G3/8"X19	G1/2"X14	13.5	16	39.5	27
1B-06-10	G3/8"X19	G5/8"X14	13.5	17.5	42	30
1B-06-12	G3/8"X19	G3/4"X14	13.5	18.5	43	32
1B-08	G1/2"X14	G1/2"X14	16	16	42	27
1B-08-10	G1/2"X14	G5/8"X14	16	17.5	43.5	30
1B-08-12	G1/2"X14	G3/4"X14	16	18.5	45.5	32
1B-10	G5/8"X14	G5/8"X14	17.5	17.5	45	30
1B-10-12	G5/8"X14	G3/4"X14	17.5	18.5	47	32
1B-10-16	G5/8"X14	G1"X11	17.5	20.5	51.5	41
1B-12	G3/4"X14	G3/4"X14	18.5	18.5	48	32
1B-12-16	G3/4"X14	G1"X11	18.5	20.5	52.5	41
1B-12-20	G3/4"X14	G1.1/4"X11	18.5	20.5	56	50
1B-16	G1"X11	G1"X11	20.5	20.5	54	41
1B-16-20	G1"X11	G1.1/4"X11	20.5	20.5	58	50
1B-16-24	G1"X11	G1.1/2"X11	20.5	23	60.5	55
1B-20	G1.1/4"X11	G1.1/4"X11	20.5	20.5	58	50
1B-20-24	G1.1/4"X11	G1.1/2"X11	20.5	23	60.5	55
1B-24	G1.1/2"X11	G1.1/2"X11	23	23	63	55
1B-24-32	G1.1/2"X11	G2"X11	23	25.5	66.5	70
1B-32	G2"X11	G2"X11	25.5	25.5	68	70
1B-40	G2.1/2"X11	G2.1/2"X11	32	32	81	90
1B-48	G3"X11	G3"X11	36	36	92	100

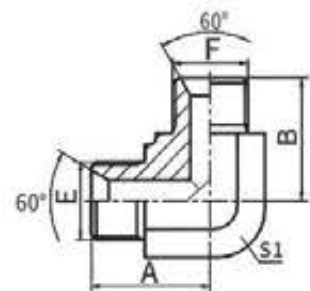
1B9

90° 弯英管外螺纹60° 内锥
 90° ELBOW BSPP MALE 60° SEAT

代号 PART NO.	螺纹 THREAD		尺寸 DIMENSIONS		
	E	F	A	B	S1
1B9-02	G1/8"X28	G1/8"X28	19.8	19.8	11
1B9-02-04	G1/8"X28	G1/4"X19	23	25	14
1B9-04	G1/4"X19	G1/4"X19	24.5	24.5	14
1B9-04-06	G1/4"X19	G3/8"X19	26.5	27.5	16
1B9-06	G3/8"X19	G3/8"X19	27.5	27.5	16
1B9-08	G1/2"X14	G1/2"X14	34.5	34.5	22
1B9-08-12	G1/2"X14	G3/4"X14	37.5	40	27
1B9-10	G5/8"X14	G5/8"X14	35	35	22
1B9-10-12	G5/8"X14	G3/4"X14	37.5	39	30
1B9-12	G3/4"X14	G3/4"X14	40	40	27
1B9-12-16	G3/4"X14	G1"X11	43.5	46	33
1B9-16	G1"X11	G1"X11	46	46	33
1B9-16-20	G1"X11	G1.1/4"X11	50.5	50.5	41
1B9-20	G1.1/4"X11	G1.1/4"X11	50.5	50.5	41
1B9-20-24	G1.1/4"X11	G1.1/2"X11	54.5	57.5	48
1B9-24	G1.1/2"X11	G1.1/2"X11	57.5	57.5	48
1B9-32	G2"X11	G2"X11	68	68	63

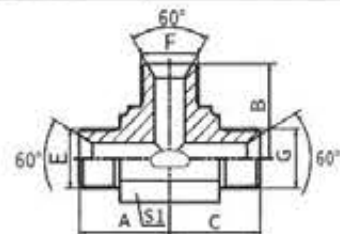
AB

英管外螺纹60° 内锥三通
 BSPP MALE 60° SEAT TEE

代号 PART NO.	螺纹 THREAD			尺寸 DIMENSIONS			
	E	F	G	A	B	C	S1
AB-02	G1/8"X28	G1/8"X28	G1/8"X28	19.8	19.8	19.8	11
AB-04	G1/4"X19	G1/4"X19	G1/4"X19	24.5	24.5	24.5	14
AB-04-06-04	G1/4"X19	G3/8"X19	G1/4"X19	26.5	27.5	26.5	16
AB-06-04-06	G3/8"X19	G1/4"X19	G3/8"X19	27.5	26.5	27.5	16
AB-06	G3/8"X19	G3/8"X19	G3/8"X19	27.5	27.5	27.5	16
AB-08-06-08	G1/2"X14	G3/8"X19	G1/2"X14	34.5	31	34.5	22
AB-08	G1/2"X14	G1/2"X14	G1/2"X14	34.5	34.5	34.5	22
AB-10	G5/8"X14	G5/8"X14	G5/8"X14	35	35	35	22
AB-12	G3/4"X14	G3/4"X14	G3/4"X14	40	40	40	27
AB-12-16-12	G3/4"X14	G1"X11	G3/4"X14	43.5	46	43.5	33
AB-16-12-16	G1"X11	G3/4"X14	G1"X11	46	43.5	46	33
AB-16	G1"X11	G1"X11	G1"X11	46	46	46	33
AB-20	G1.1/4"X11	G1.1/4"X11	G1.1/4"X11	50.5	50.5	50.5	41
AB-24	G1.1/2"X11	G1.1/2"X11	G1.1/2"X11	57.5	57.5	57.5	48
AB-32	G2"X11	G2"X11	G2"X11	72.5	72.5	72.5	63

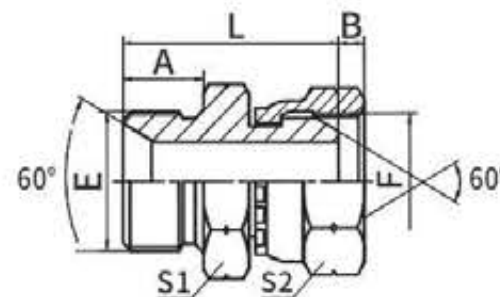
2B

英管外螺纹60° 内锥或六角端面组合密封/
 英制内螺纹60° 外锥
 BSP MALE DOUBLE USE FOR 60° SEAT
 OR BONDED SEAL/BSP FEMALE 60° CONE

代号 PART NO.	螺纹 THREAD		尺寸 DIMENSIONS				
	E	F	A	B	L	S1	S2
2B-02	G1/8"X28	G1/8"X28	10	5.5	25	14	14
2B-02-04	G1/8"X28	G1/4"X19	10	5.5	27	14	19
2B-04	G1/4"X19	G1/4"X19	12	5.5	29	19	19
2B-04-06	G1/4"X19	G3/8"X19	12	6.3	30.5	19	22
2B-04-08	G1/4"X19	G1/2"X14	12	7.5	32	19	27
2B-06-08	G3/8"X19	G1/2"X14	13.5	7.5	35.5	22	27
2B-06-10	G3/8"X19	G5/8"X14	13.5	9.5	36	22	30
2B-08	G1/2"X14	G1/2"X14	16	7.5	40	27	27
2B-08-06	G1/2"X14	G3/8"X19	16	6.3	38.5	27	22
2B-08-12	G1/2"X14	G3/4"X14	16	10.9	41	27	32
2B-10	G5/8"X14	G5/8"X14	17.5	9.5	42	30	30
2B-10-08	G5/8"X14	G1/2"X14	17.5	7.5	41.5	30	27
2B-10-12	G5/8"X14	G3/4"X14	17.5	10.9	42.5	30	32
2B-12	G3/4"X14	G3/4"X14	18.5	10.9	44.5	32	32
2B-12-10	G3/4"X14	G5/8"X14	18.5	9.5	44	32	30
2B-12-16	G3/4"X14	G1"X11	18.5	11.7	46	32	41
2B-16	G1"X11	G1"X11	20.5	11.7	50	41	41
2B-16-12	G1"X11	G3/4"X14	20.5	10.9	49	41	32
2B-16-20	G1"X11	G1.1/4"X11	20.5	11	53	41	50
2B-20	G1.1/4"X11	G1.1/4"X11	20.5	11	55	50	50
2B-20-16	G1.1/4"X11	G1"X11	20.5	11.7	52	50	41
2B-20-24	G1.1/4"X11	G1.1/2"X11	20.5	13	55.5	50	55
2B-24	G1.1/2"X11	G1.1/2"X11	23	13	58	55	55
2B-32	G2"X11	G2"X11	25.5	16	63.5	70	70

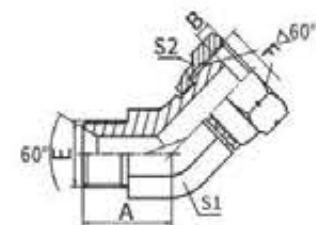
2B4

45° 弯英管外螺纹60° 内锥/英管内螺纹60° 外锥
 45° ELBOW BSP MALE 60°
 SEAT / BSP FEMALE 60° CONE

代号 PART NO.	螺纹 THREAD		尺寸 DIMENSIONS				
	E	F	A	B	S1	S2	
2B4-04	G1/4"X19	G1/4"X19	20.3	5.5	14	19	
2B4-04-06	G1/4"X19	G3/8"X19	20.3	6.3	14	22	
2B4-06	G3/8"X19	G3/8"X19	22	6.3	16	22	
2B4-06-04	G3/8"X19	G1/4"X19	22	5.5	16	19	
2B4-08	G1/2"X14	G1/2"X14	27	7.5	22	27	
2B4-08-06	G1/2"X14	G3/8"X19	27	6.3	22	22	
2B4-10	G5/8"X14	G5/8"X14	28.5	9.5	22	30	
2B4-10-08	G5/8"X14	G1/2"X14	28.5	7.5	22	27	
2B4-12	G3/4"X14	G3/4"X14	31	10.9	27	32	
2B4-16	G1"X11	G1"X11	35	11.7	33	41	
2B4-20	G1.1/4"X11	G1.1/4"X11	38.5	11	41	50	
2B4-24	G1.1/2"X11	G1.1/2"X11	44	13	48	55	
2B4-32	G2"X11	G2"X11	51	16	63	70	

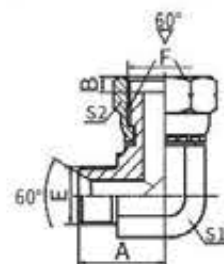
2B9

90° 弯英管外螺纹60° 内锥/英管内螺纹60° 外锥
 90° ELBOW BSPP MALE 60°
 SEAT/BSPP FEMALE 60° CONE

代号 PART NO.	螺纹 THREAD		尺寸 DIMENSIONS			
	E	F	A	B	S1	S2
2B9-02	G1/8"X28	G1/8"X28	19.8	5.5	11	14
2B9-04	G1/4"X19	G1/4"X19	24.5	5.5	14	19
2B9-04-06	G1/4"X19	G3/8"X19	25	6.3	14	22
2B9-06	G3/8"X19	G3/8"X19	27.5	6.3	16	22
2B9-06-04	G3/8"X19	G1/4"X19	27.5	5.5	16	19
2B9-08	G1/2"X14	G1/2"X14	34.5	7.5	22	27
2B9-08-06	G1/2"X14	G3/8"X19	34.5	6.3	22	22
2B9-10	G5/8"X14	G5/8"X14	35	9.5	22	30
2B9-10-08	G5/8"X14	G1/2"X14	35	7.5	22	27
2B9-12	G3/4"X14	G3/4"X14	40	10.9	27	32
2B9-16	G1"X11	G1"X11	46	11.7	33	41
2B9-20	G1.1/4"X11	G1.1/4"X11	50.5	11	41	50
2B9-24	G1.1/2"X11	G1.1/2"X11	57.5	13	48	55
2B9-32	G2"X11	G2"X11	72.5	16	63	70

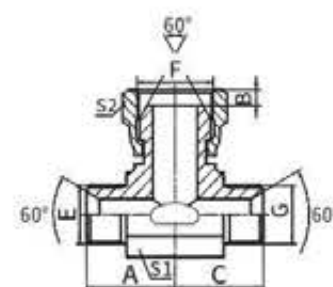
BB

英管外螺纹60°内锥/英管内螺纹60°外锥三通
 BSPP MALE 60° SEAT/ BSPP FEMALE 60°
 CONE BRANCH TEE

代号 PART NO.	螺纹 THREAD			尺寸 DIMENSIONS				
	E	F	G	A	B	C	S1	S2
BB-02	G1/8"X28	G1/8"X28	G1/8"X28	19.8	5.5	19.8	11	14
BB-04	G1/4"X19	G1/4"X19	G1/4"X19	24.5	5.5	24.5	14	19
BB-06	G3/8"X19	G3/8"X19	G3/8"X19	27.5	6.3	27.5	16	22
BB-08	G1/2"X14	G1/2"X14	G1/2"X14	34.5	7.5	34.5	22	27
BB-12	G3/4"X14	G3/4"X14	G3/4"X14	40	10.9	40	27	32
BB-16	G1"X11	G1"X11	G1"X11	46	11.7	46	33	41
BB-20	G1.1/4"X11	G1.1/4"X11	G1.1/4"X11	50.5	11	50.5	41	50
BB-24	G1.1/2"X11	G1.1/2"X11	G1.1/2"X11	57.5	13	57.5	48	55
BB-32	G2"X11	G2"X11	G2"X11	72.5	16	72.5	63	70

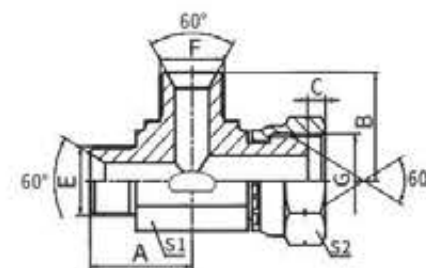
CB

英管外螺纹60° 内锥/英管内螺纹60° 外锥三通
 BSPP MALE 60° SEAT / BSPP FEMALE 60°
 CONE RUN TEE

代号 PART NO.	螺纹 THREAD			尺寸 DIMENSIONS				
	E	F	G	A	B	C	S1	S2
CB-02	G1/8"X28	G1/8"X28	G1/8"X28	19.8	19.5	5.5	11	14
CB-04	G1/4"X19	G1/4"X19	G1/4"X19	25	25	5.5	14	19
CB-06	G3/8"X19	G3/8"X19	G3/8"X19	27.5	27.5	6.3	16	22
CB-08	G1/2"X14	G1/2"X14	G1/2"X14	34.5	34.5	7.5	22	27
CB-10	G5/8"X14	G5/8"X14	G5/8"X14	34.5	34.5	9.5	22	30
CB-12	G3/4"X14	G3/4"X14	G3/4"X14	40	40	10.9	27	32
CB-16	G1"X11	G1"X11	G1"X11	46	46	11.7	33	41
CB-20	G1.1/4"X11	G1.1/4"X11	G1.1/4"X11	50.5	50.5	11	41	50
CB-24	G1.1/2"X11	G1.1/2"X11	G1.1/2"X11	57.5	57.5	13	48	55
CB-32	G2"X11	G2"X11	G2"X11	72.5	72.5	16	63	70

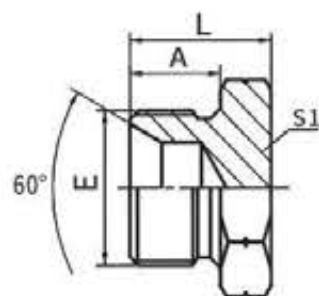
4B

英管外螺纹60° 内锥或
 六角端面用组合垫密封堵头
**BSP MALE DOUBLE USE FOR 60°
 SEAT OR BONDED SEAL PLUG**

代号 PART NO.	螺纹 THREAD	尺寸 DIMENSIONS		
	E	A	L	S1
4B-02	G1/8"X28	10	16	14
4B-04	G1/4"X19	12	18	19
4B-06	G3/8"X19	13.5	21.5	22
4B-08	G1/2"X14	16	26	27
4B-10	G5/8"X14	17.5	27.5	30
4B-12	G3/4"X14	18.5	29.5	32
4B-16	G1"X11	20.5	34	41
4B-20	G1.1/4"X11	20.5	37.5	50
4B-24	G1.1/2"X11	23	40	55
4B-32	G2"X11	25.5	43.5	70

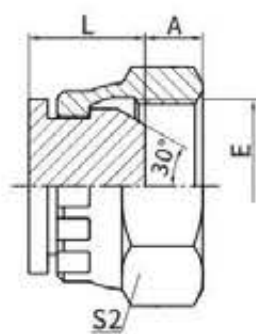
9B

英管内螺纹60° 外锥堵头
BSPP FEMALE 60°CONE PLUG

代号 PART NO.	螺纹 THREAD	尺寸 DIMENSIONS		
	E	A	L	S2
9B-02	G1/8"X28	5.5	11.5	14
9B-04	G1/4"X19	5.5	12	19
9B-06	G3/8"X19	6.3	14	22
9B-08	G1/2"X14	7.5	15.5	27
9B-10	G5/8"X14	9.5	16	30
9B-12	G3/4"X14	10.9	18	32
9B-16	G1"X11	11.7	21	41
9B-20	G1.1/4"X11	11	25	50
9B-24	G1.1/2"X11	13	25.5	55
9B-32	G2"X11	16	29	70

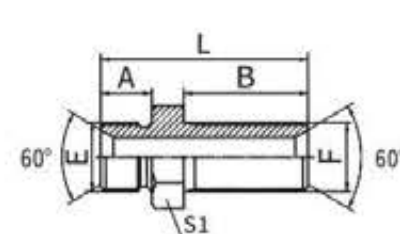
6B

6B-LN

英管外螺纹60° 内锥过板接头
BSPP MALE 60° SEAT BULKHEAD

代号 PART NO.	螺纹 THREAD		尺寸 DIMENSIONS				
	E	F	A	B	L	S1	S2
6B-02	G1/8"X28	G1/8"X28	10	33	49	14	14
6B-04	G1/4"X19	G1/4"X19	12	35	53	19	19
6B-06	G3/8"X19	G3/8"X19	13.5	35	56.5	22	22
6B-08	G1/2"X14	G1/2"X14	16	39	65	27	27
6B-12	G3/4"X14	G3/4"X14	18.5	42	71.5	32	32
6B-16	G1"X11	G1"X11	20.5	50	84	41	41
6B-20	G1.1/4"X11	G1.1/4"X11	20.5	52	89.5	50	50
6B-24	G1.1/2"X11	G1.1/2"X11	23	55	93	55	55
6B-32	G2"X11	G2"X11	25.5	55	98.5	70	70

注：如需带锁母整套订货，则请在代号后加“LN”，如6B-16LN,锁母代号为8B。
 Note: In case if you are interested to order the adapter in complete set with lock nut, it is necessary to insert suffix "LN" after our part NO., for example 6B-16LN, The lock nut NO. is 8B.

8B

英管螺纹锁母
BSP LOCK NUT

代号 PART NO.	螺纹 THREAD	尺寸 DIMENSIONS	
	E	A	S1
8B-02	G1/8"X28	5.5	14
8B-04	G1/4"X19	6.5	19
8B-06	G3/8"X19	7	22
8B-08	G1/2"X14	9	27
8B-10	G5/8"X14	9	30
8B-12	G3/4"X14	10.5	32
8B-16	G1"X11	10.5	41
8B-20	G1.1/4"X11	10.5	50
8B-24	G1.1/2"X11	10.5	55
8B-32	G2"X11	10.5	70

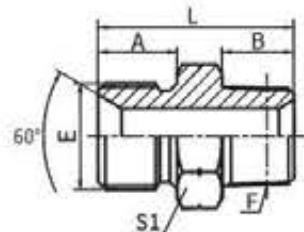
1BT-SP

英管外螺纹60°内锥/英锥管外螺纹
 BSPP MALE DOUBLE USE FOR 60° SEAT
 OR BONDED SEAL/BSPT MALE

代号 PART NO.	螺纹 THREAD		尺寸 DIMENSIONS			
	E	F	A	B	L	S1
1BT-02SP	G1/8"X28	R1/8"X28	10	10	26	14
1BT-02-04SP	G1/8"X28	R1/4"X19	10	14.5	30.5	14
1BT-04SP	G1/4"X19	R1/4"X19	12	14.5	32	19
1BT-04-02SP	G1/4"X19	R1/8"X28	12	10	28	19
1BT-04-06SP	G1/4"X19	R3/8"X19	12	15	32	19
1BT-04-08SP	G1/4"X19	R1/2"X14	12	20	40	24
1BT-06SP	G3/8"X19	R3/8"X19	13.5	15	35.5	22
1BT-06-04SP	G3/8"X19	R1/4"X19	13.5	14.5	35.5	22
1BT-06-08SP	G3/8"X19	R1/2"X14	13.5	20	40.5	24
1BT-08SP	G1/2"X14	R1/2"X14	16	20	45	27
1BT-08-04SP	G1/2"X14	R1/4"X19	16	14.5	40.5	27
1BT-08-06SP	G1/2"X14	R3/8"X19	16	15	40	27
1BT-08-12SP	G1/2"X14	R3/4"X14	16	20	45	30
1BT-10-06SP	G5/8"X14	R3/8"X19	17.5	15	41.5	30
1BT-10-08SP	G5/8"X14	R1/2"X14	17.5	20	46.5	30
1BT-10-12SP	G5/8"X14	R3/4"X14	17.5	20	46.5	30
1BT-10-16SP	G5/8"X14	R1"X11	17.5	25.5	57	36
1BT-12SP	G3/4"X14	R3/4"X14	18.5	20	48.5	32
1BT-12-08SP	G3/4"X14	R1/2"X14	18.5	20	49.5	32
1BT-12-16SP	G3/4"X14	R1"X11	18.5	25.5	53.5	36
1BT-12-20SP	G3/4"X14	R1.1/4"X11	18.5	26.5	58	46
1BT-16SP	G1"X11	R1"X11	20.5	25.5	58	41
1BT-16-12SP	G1"X11	R3/4"X14	20.5	20	53	41
1BT-16-20SP	G1"X11	R1.1/4"X11	20.5	26.5	60	46
1BT-20SP	G1.1/4"X11	R1.1/4"X11	20.5	26.5	62	50
1BT-20-12SP	G1.1/4"X11	R3/4"X14	20.5	20.5	56	50
1BT-20-16SP	G1.1/4"X11	R1"X11	20.5	25.5	61	50
1BT-20-24SP	G1.1/4"X11	R1.1/2"X11	20.5	26.5	62	50
1BT-24SP	G1.1/2"X11	R1.1/2"X11	23	26.5	64.5	55
1BT-24-16SP	G1.1/2"X11	R1"X11	23	25.5	63.5	55
1BT-24-20SP	G1.1/2"X11	R1.1/4"X11	23	26.5	64.5	55
1BT-24-32SP	G1.1/2"X11	R2"X11	23	30	70	65
1BT-32SP	G2"X11	R2"X11	25.5	30	72.5	70
1BT-32-20SP	G2"X11	R1.1/4"X11	25.5	27	68.5	70
1BT-32-24SP	G2"X11	R1.1/2"X11	25.5	26.5	68.5	70
1BT-40SP	G2.1/2"X11	R2.1/2"X11	32	34	83	90
1BT-48SP	G3"X11	R3"X11	36	38	94	100

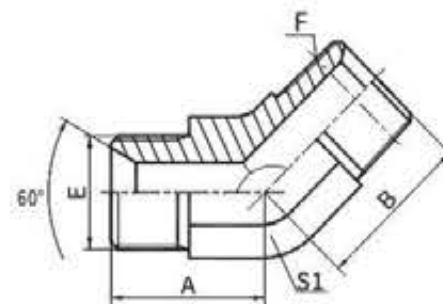
1BT4-SP

45° 弯英管外螺纹60° 内锥/英锥管外螺纹
 45° ELBOW BSP MALE 60° SEAT /BSPT MALE

代号 PART NO.	螺纹 THREAD		尺寸 DIMENSIONS			
	E	F	A	B	S1	
1BT4-02SP	G1/8"X28	R1/8"X28	17	17	11	
1BT4-04SP	G1/4"X19	R1/4"X19	20.3	21	14	
1BT4-04-06SP	G1/4"X19	R3/8"X19	20.5	23	16	
1BT4-06SP	G3/8"X19	R3/8"X19	22	23	16	
1BT4-06-04SP	G3/8"X19	R1/4"X19	22	21	16	
1BT4-06-08SP	G3/8"X19	R1/2"X14	24	29.5	22	
1BT4-06-12SP	G3/8"X19	R3/4"X14	25.5	30.5	27	
1BT4-08SP	G1/2"X14	R1/2"X14	27	29.5	22	
1BT4-08-06SP	G1/2"X14	R3/8"X19	27	25	22	
1BT4-08-12SP	G1/2"X14	R3/4"X14	28.5	30.5	27	
1BT4-10-08SP	G5/8"X14	R1/2"X14	28.5	29.5	22	
1BT4-10-12SP	G5/8"X14	R3/4"X14	29	35	27	
1BT4-12SP	G3/4"X14	R3/4"X14	31	30.5	27	
1BT4-12-08SP	G3/4"X14	R1/2"X14	31	30.5	27	
1BT4-12-16SP	G3/4"X14	R1"X11	32.5	38	33	
1BT4-16SP	G1"X11	R1"X11	35	38	33	
1BT4-16-12SP	G1"X11	R3/4"X14	35	32.5	33	
1BT4-16-20SP	G1"X11	R1.1/4"X11	38.5	43	41	
1BT4-20SP	G1.1/4"X11	R1.1/4"X11	38.5	43	41	
1BT4-20-16SP	G1.1/4"X11	R1"X11	38.5	42	41	
1BT4-20-24SP	G1.1/4"X11	R1.1/2"X11	41.5	47.5	48	
1BT4-24SP	G1.1/2"X11	R1.1/2"X11	44	47.5	48	
1BT4-24-20SP	G1.1/2"X11	R1.1/4"X11	44	45.5	48	
1BT4-24-32SP	G1.1/2"X11	R2"X11	51	60.5	63	
1BT4-32SP	G2"X11	R2"X11	49.5	55.5	63	
1BT4-32-24SP	G2"X11	R1.1/2"X11	51	52.5	63	

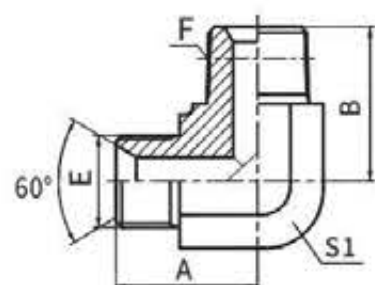
1BT9-SP

90° 弯英管外螺纹60°内锥/英锥管外螺纹
 90° ELBOW BSPP MALE 60° SEAT / BSPT MALE

代号 PART NO.	螺纹 THREAD		尺寸 DIMENSIONS		
	E	F	A	B	S1
1BT9-02SP	G1/8"X28	R1/8"X28	20	21	11
1BT9-02-04SP	R1/8"X28	R1/4"X19	22.3	25.5	14
1BT9-04SP	G1/4"X19	R1/4"X19	24.5	25.5	14
1BT9-04-02SP	G1/4"X19	R1/8"X28	25	23.5	14
1BT9-04-06SP	G1/4"X19	R3/8"X19	25	28.5	16
1BT9-06SP	G3/8"X19	R3/8"X19	27.5	28.5	16
1BT9-06-04SP	G3/8"X19	R1/4"X19	27.5	26.5	16
1BT9-06-08SP	G3/8"X19	R1/2"X14	31	36	22
1BT9-08SP	G1/2"X14	R1/2"X14	34.5	36	22
1BT-08-04SP	G1/2"X14	R1/4"X19	34.5	30.5	22
1BT-08-06SP	G1/2"X14	R3/8"X19	34.5	32.5	22
1BT9-08-12SP	G1/2"X14	R3/4"X14	37.5	43.5	27
1BT9-08-16SP	G1/2"X14	R1"X11	41	50	33
1BT9-10-08SP	G5/8"X14	R1/2"X14	35	36	22
1BT8-10-12SP	G5/8"X14	R3/4"X14	39	43.5	27
1BT9-12SP	G3/4"X14	R3/4"X14	40	43	27
1BT9-12-06SP	G3/4"X14	R3/8"X19	40	36	27
1BT9-12-08SP	G3/4"X14	R1/2"X14	40	39.5	27
1BT9-12-16SP	G3/4"X14	R1"X11	43.5	50	33
1BT9-12-20SP	G3/4"X14	R1.1/4"X11	48	56.5	41
1BT9-16SP	G1"X11	R1"X11	46	50	33
1BT9-16-08SP	G1"X11	R1/2"X14	46	43	33
1BT9-16-12SP	G1"X11	R3/4"X14	46	47.5	33
1BT9-16-20SP	G1"X11	R1.1/4"X11	50.5	56.5	41
1BT9-20SP	G1.1/4"X11	R1.1/4"X11	52	59	41
1BT9-20-12SP	G1.1/4"X11	R3/4"X14	50.5	54	41
1BT9-20-16SP	G1.1/4"X11	R1"X11	52	56.5	41
1BT9-20-24SP	G1.1/4"X11	R1.1/2"X11	54.5	62.5	48
1BT9-24SP	G1.1/2"X11	R1.1/2"X11	57.5	62	48
1BT9-24-20SP	G1.1/2"X11	R1.1/4"X11	57.5	61	48
1BT9-24-32SP	G1.1/2"X11	R2"X11	66	75	63
1BT9-32SP	G2"X11	R2"X11	67	75	63
1BT9-32-24SP	G2"X11	R1.1/2"X11	68	72	63

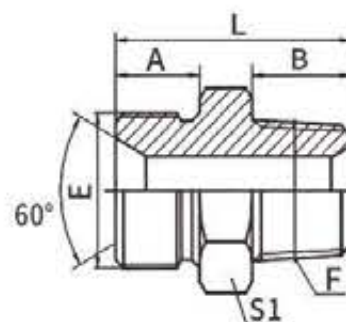
1BN

英管外螺纹60° 内锥或六角端面用组合垫密封/
 美制布锥管外螺纹
 BSP MALE DOUBLE USE FOR 60° CONE SEAT OR
 BONDED SEAL / NPT MALE

代号 PART NO.	螺纹 THREAD		尺寸 DIMENSIONS			
	E	F	A	B	L	S1
1BN-02	G1/8"X28	Z1/8"X27	10	10.5	26	14
1BN-02-04	G1/8"X28	Z1/4"X18	10	15	31	17
1BN-04	G1/4"X19	Z1/4"X18	12	15	33	19
1BN-04-02	G1/4"X19	Z1/8"X27	12	10.5	28	19
1BN-04-06	G1/4"X19	Z3/8"X18	12	16	34	19
1BN-06	G3/8"X19	Z3/8"X18	13.5	16	37.5	22
1BN-06-04	G3/8"X19	Z1/4"X18	13.5	15	36	22
1BN-06-08	G3/8"X19	Z1/2"X14	13.5	19.5	41	22
1BN-06-12	G3/8"X19	Z3/4"X14	13.5	19.5	43	30
1BN-08	G1/2"X14	Z1/2"X14	16	19.5	45.5	27
1BN-08-06	G1/2"X14	Z3/8"X18	16	16	42	27
1BN-08-12	G1/2"X14	Z3/4"X14	16	19.5	45.5	30
1BN-08-16	G1/2"X14	Z1"X11.5	16	25.5	52.5	36
1BN-10-08	G5/8"X14	Z1/2"X14	17.5	19.5	47	30
1BN-10-12	G5/8"X14	Z3/4"X14	17.5	19.5	47	30
1BN-12	G3/4"X14	Z3/4"X14	18.5	19.5	49	32
1BN-12-06	G3/4"X14	Z3/8"X18	18.5	16	45.5	32
1BN-12-08	G3/4"X14	Z1/2"X14	18.5	19.5	49	32
1BN-12-16	G3/4"X14	Z1"X11.5	18.5	25.5	55	36
1BN-16	G1"X11	Z1"X11.5	20.5	25.5	59	41
1BN-16-12	G1"X11	Z3/4"X14	20.5	19.5	53	41
1BN-16-20	G1"X11	Z1.1/4"X11.5	20.5	26.5	60	46
1BN-20	G1.1/4"X11	Z1.1/4"X11.5	20.5	26.5	62	50
1BN-20-16	G1.1/4"X11	Z1"X11.5	20.5	25.5	61	50
1BN-20-24	G1.1/4"X11	Z1.1/2"X11.5	20.5	27.5	63	50
1BN-24	G1.1/2"X11	Z1.1/2"X11.5	23	27.5	65.5	55
1BN-24-20	G1.1/2"X11	Z1.1/4"X11.5	23	26.5	64.5	55
1BN-24-32	G1.1/2"X11	Z2"X11.5	23	27.5	67.5	65
1BN-32	G2"X11	Z2"X11.5	25.5	27.5	70	70
1BN-32-20	G2"X11	Z1.1/4"X11.5	25.5	26.5	69	70
1BN-32-24	G2"X11	Z1.1/2"X11.5	25.5	27.5	70	70

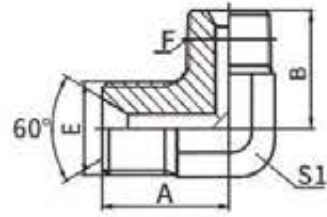
1BN9

90° 弯英管外螺纹60° 内锥/美制布锥管外螺纹
 90° ELBOW BSP MALE 60°SEAT
 NPT MALE

代号 PART NO.	螺纹 THREAD		尺寸 DIMENSIONS			
	E	F	A	B	S1	
1BN9-04	G1/4"X19	Z1/4"X18	24.5	25.5	14	
1BN9-04-02	G1/4"X19	Z1/8"X27	24.5	23.5	14	
1BN9-06	G3/8"X19	Z3/8"X18	28.5	31	19	
1BN9-06-04	G3/8"X19	Z1/4"X18	27.5	26.5	16	
1BN9-06-08	G3/8"X19	Z1/2"X14	31	36.5	22	
1BN9-08	G1/2"X14	Z1/2"X14	34.5	37.5	22	
1BN9-08-06	G1/2"X14	Z3/8"X18	34.5	33	22	
1BN9-12	G3/4"X14	Z3/4"X14	38	43.5	27	
1BN9-12-08	G3/4"X14	Z1/2"X14	39	40	27	
1BN9-12-16	G3/4"X14	Z1"X11.5	43	50	33	
1BN9-16	G1"X11	Z1"X11.5	46	50	33	
1BN9-16-12	G1"X11	Z3/4"X14	46	46.5	33	
1BN9-20	G1.1/4"X11	Z1.1/4"X11.5	50.5	54	41	
1BN9-24	G1.1/2"X11	Z1.1/2"X11.5	57.5	59.5	48	

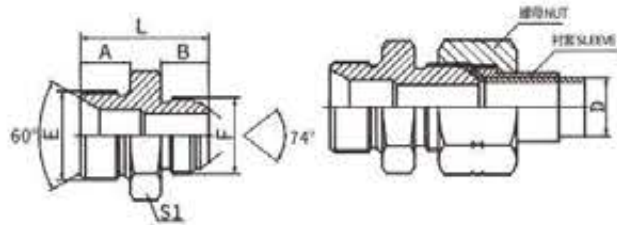
1BJ

英管外螺纹60° 内锥或六角端面用组合垫密封/
 美制JIC外螺纹74° 外锥
 BSP MALE DOUBLE USE FOR 60° SEAT
 OR BONDED SEAL /JIC MALE 74° CONE

代号 PART NO.	螺纹 THREAD		尺寸 DIMENSIONS			
	E	F	A	B	L	S1
1BJ-02-04	G1/8"X28	7/16"X20	10	14	30	14
1BJ-02-05	G1/8"X28	1/2"X20	10	14	30	14
1BJ-02-06	G1/8"X28	9/16"X18	10	14.1	30	17
1BJ-04	G1/4"X19	7/16"X20	12	14	32	19
1BJ-04-05	G1/4"X19	1/2"X20	12	14	32	19
1BJ-04-08	G1/4"X19	3/4"X16	12	16.7	36.5	22
1BJ-04-10	G1/4"X19	7/8"X14	12	19.3	39	24
1BJ-06	G3/8"X19	9/16"X18	13.5	14.1	35.5	22
1BJ-06-04	G3/8"X19	7/16"X20	13.5	14	35.5	22
1BJ-06-05	G3/8"X19	1/2"X20	13.5	14	35.5	22

接下页

接上页

代号 PART NO.	螺纹 THREAD		尺寸 DIMENSIONS			
	E	F	A	B	L	S1
1BJ-06-08	G3/8"X19	3/4"X16	13.5	16.7	38.5	22
1BJ-06-10	G3/8"X19	7/8"X14	13.5	19.3	41	24
1BJ-06-12	G3/8"X19	1.1/16"X12	13.5	21.9	45	30
1BJ-08	G1/2"X14	3/4"X16	16	16.7	43	27
1BJ-08-04	G1/2"X14	7/16"X20	16	14	40	27
1BJ-08-05	G1/2"X14	1/2"X20	16	14	40	27
1BJ-08-06	G1/2"X14	9/16"X18	16	14.1	40	27
1BJ-08-10	G1/2"X14	7/8"X14	16	19.3	45.5	27
1BJ-08-12	G1/2"X14	1.1/16"X12	16	21.9	48	30
1BJ-08-14	G1/2"X14	1.3/16"X12	16	22.6	49.5	32
1BJ-08-16	G1/2"X14	1.5/16"X12	16	23.1	50	36
1BJ-10	G5/8"X14	7/8"X14	17.5	19.3	47	30
1BJ-10-08	G5/8"X14	3/4"X16	17.5	16.7	44	30
1BJ-10-12	G5/8"X14	1.1/16"X12	17.5	21.9	49.5	30
1BJ-10-16	G5/8"X14	1.5/16"X12	17.5	23.1	51.5	36
1BJ-12	G3/4"X14	1.1/16"X12	18.5	21.9	51.5	32
1BJ-12-06	G3/4"X14	9/16"X18	18.5	14.1	43.5	32
1BJ-12-08	G3/4"X14	3/4"X16	18.5	16.7	46.5	32
1BJ-12-10	G3/4"X14	7/8"X14	18.5	19.3	49	32
1BJ-12-14	G3/4"X14	1.3/16"X12	18.5	22.6	52	32
1BJ-12-16	G3/4"X14	1.5/16"X12	18.5	23.1	52.5	34
1BJ-12-20	G3/4"X14	1.5/8"X12	18.5	24.3	55.5	46
1BJ-16	G1"X11	1.5/16"X12	20.5	23.1	57	41
1BJ-16-08	G1"X11	3/4"X16	20.5	16.7	50	41
1BJ-16-10	G1"X11	7/8"X14	20.5	19.3	53	41
1BJ-16-12	G1"X11	1.1/16"X12	20.5	21.9	55.5	41
1BJ-16-14	G1"X11	1.3/16"X12	20.5	22.6	56	41
1BJ-16-20	G1"X11	1.5/8"X12	20.5	24.3	58	46
1BJ-20	G1.1/4"X11	1.5/8"X12	20.5	24.3	62	50
1BJ-20-12	G1.1/4"X11	1.1/16"X12	20.5	21.9	57.5	50
1BJ-20-16	G1.1/4"X11	1.5/16"X12	20.5	23.1	60.5	50
1BJ-20-24	G1.1/4"X11	1.7/8"X12	20.5	27.5	63	50
1BJ-24-16	G1.1/2"X11	1.5/16"X12	23	23.1	61	55
1BJ-24-20	G1.1/2"X11	1.5/8"X12	23	24.3	62.5	55
1BJ-24	G1.1/2"X11	1.7/8"X12	23	27.5	67.5	55
1BJ-24-32	G1.1/2"X11	2.1/2"X12	23	33.9	74	65
1BJ-32	G2"X11	2.1/2"X12	25.5	33.9	77.5	70
1BJ-32-24	G2"X11	1.7/8"X12	25.5	27.5	70	70

注:螺母及衬套需另行订货。管子直径D为公制时, 配用螺母及衬套分别选用NB200、NB500。管子直径为英制时, 配用螺母及衬套分别选用NB200、NB300。 Nut and sleeve should be ordered separately. The nut NB200 and sleeve NB500 is suitable for metric tube, the nut NB200 and sleeve NB300 is suitable for inch tube.

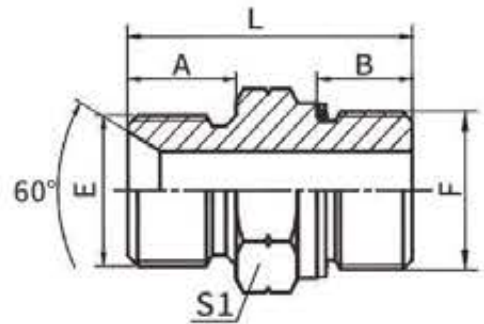
1BG

英管外螺纹60° 内锥或六角端面用组合垫密封/
 英管外螺纹O形圈
 BSP MALE DOUBLE USE FOR 60° SEAT OR
 BONDED SEAL / BSP MALE O-RING

代号 PART NO.	螺纹 THREAD		O形圈 O-RING F端	尺寸 DIMENSIONS			
	E	F		A	B	L	S1
1BG-02	G1/8"X28	G1/8"X28	O011	10	9.5	27	14
1BG-04	G1/4"X19	G1/4"X19	O111	12	11	31	19
1BG-04-06	G1/4"X19	G3/8"X19	O113	12	11.5	32	22
1BG-06	G3/8"X19	G3/8"X19	O113	13.5	11.5	33	22
1BG-06-04	G3/8"X19	G1/4"X19	O111	13.5	11	32.5	22
1BG-08	G1/2"X14	G1/2"X14	O115	16	14	41	27
1BG-08-06	G1/2"X14	G3/8"X19	O113	16	11.5	36	27
1BG-08-12	G1/2"X14	G3/4"X14	O119	16	15.5	45.5	32
1BG-10-08	G5/8"X14	G1/2"X14	O115	17.5	14	44.5	30
1BG-12	G3/4"X14	G3/4"X14	O119	18.5	15.5	46	32
1BG-12-08	G3/4"X14	G1/2"X14	O115	18.5	14	45.5	32
1BG-16-08	G1"X11	G1/2"X14	O115	20.5	14	50.5	41
1BG-16	G1"X11	G1"X11	O217	20.5	18	53	41
1BG-16-12	G1"X11	G3/4"X14	O119	20.5	15.5	52	41
1BG-20	G1.1/4"X11	G1.1/4"X11	O222	20.5	20	58.5	50
1BG-24	G1.1/2"X11	G1.1/2"X11	O224	23	21.5	62.5	55

注: F端与DIN 3852油口相配。 Fend is connected with DIN 3852 port.

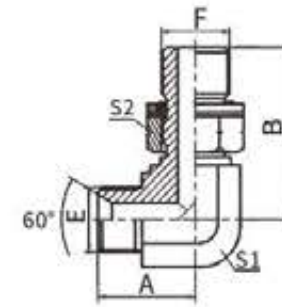
1BG9-OG

90° 弯英管外螺纹60° 内锥/
 英管外螺纹O形圈可调向柱端
 90° ELBOW BSP MALE 60° SEAT/
 BSPMALE O-RING ADJUSTABLE"STUD ENDT

代号 PART NO.	螺纹 THREAD		O形圈 O-RING F端	尺寸 DIMENSIONS			
	E	F		A	B	S1	S2
1BG9-040G	G1/4"X19	G1/4"X19	O111	25	31.5	14	19
1BG9-04-060G	G1/4"X19	G3/8"X19	O113	26.5	36.8	16	22
1BG9-060G	G3/8"X19	G3/8"X19	O113	28	36.8	16	22
1BG9-06-080G	G3/8"X19	G1/2"X14	O115	31	43.2	22	27
1BG9-080G	G1/2"X14	G1/2"X14	O115	34.5	43.2	22	27
1BG9-120G	G3/4"X14	G3/4"X14	O119	40	49.3	27	32
1BG9-12-160G	G3/4"X14	G1"X11	O217	45	53	33	41
1BG9-160G	G1"X11	G1"X11	O217	46	53	33	41
1BG9-20-160G	G1.1/4"X11	G1"X11	O217	50.5	58	41	41
1BG9-200G	G1.1/4"X11	G1.1/4"X11	O222	51.5	58	41	50
1BG9-240G	G1.1/2"X11	G1.1/2"X11	O224	58.5	63	48	55

注: F端与DIN 3852油口相配。 Note: Fend is connected with DIN 3852 port.

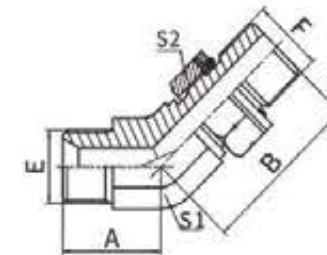
1BG4-OG

45° 弯英管外螺纹60° 内锥/英管外螺纹O形圈
 45° ELBOW BSP MALE
 60° SEAT / BSP MALE O-RING

代号 PART NO.	螺纹 THREAD		O形圈 O-RING F端	尺寸 DIMENSIONS			
	E	F		A	B	S1	S2
1BG4-040G	G1/4"X19	G1/4"X19	O111	22	28	14	19
1BG4-04-060G	G1/4"X19	G3/8"X19	O113	21	30	16	22
1BG4-04-080G	G1/4"X19	G1/2"X14	O115	22.5	36	22	27
1BG4-060G	G3/8"X19	G3/8"X19	O113	21	30	16	22
1BG4-06-080G	G3/8"X19	G1/2"X14	O115	23.5	36	22	27
1BG4-080G	G1/2"X14	G1/2"X14	O115	27	36	22	27
1BG4-120G	G3/4"X14	G3/4"X14	O119	32	42	27	32
1BG4-12-160G	G3/4"X14	G1"X11	O217	32.5	44	33	41
1BG4-160G	G1"X11	G1"X11	O217	34	44	33	41
1BG4-200G	G1.1/4"X11	G1.1/4"X11	O222	38.5	47.5	41	50
1BG4-240G	G1.1/2"X11	G1.1/2"X11	O224	44	51.5	48	55

注: F端与DIN 3852油口相配。 Note: Fend is connected with DIN 3852 port.

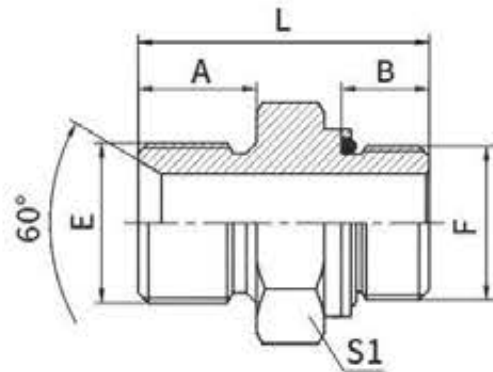
1BH

英管外螺纹60°内锥或六角端面用组合垫密封/
 公制外螺纹轻系列ISO 6149-3
 BSP MALE DOUBLE USE FOR 60°
 SEAT OR BONDED SEAL /
 METRIC MALE L-SERIES ISO 6149-3

代号 PART NO.	螺纹 THREAD		O形圈 O-RING	尺寸 DIMENSIONS				
	E	F		F端	A	B	S1	L
1BH-02-10	G1/8"X28	M10X1		O08.1X1.6	10	8.5	14	25
1BH-02-12	G1/8"X28	M12X1.5		O09.3X2.4	10	11	17	28
1BH-04-12	G1/4"X19	M12X1.5		O09.3X2.4	12	11	19	30
1BH-04-14	G1/4"X19	M14X1.5		O11.3X2.4	12	11	19	31.5
1BH-04-16	G1/4"X19	M16X1.5		O13.3X2.4	12	11.5	22	31.5
1BH-06-14	G3/8"X19	M14X1.5		O11.3X2.4	13.5	11	22	35
1BH-06-16	G3/8"X19	M16X1.5		O13.3X2.4	13.5	11.5	22	33
1BH-06-18	G3/8"X19	M18X1.5		O15.3X2.4	13.5	12.5	24	36.5
1BH-08-18	G1/2"X14	M18X1.5		O15.3X2.4	16	12.5	27	41
1BH-08-22	G1/2"X14	M22X1.5		O19.3X2.4	16	13	27	41.5
1BH-10-22	G5/8"X14	M22X1.5		O19.3X2.4	17.5	13	30	43
1BH-12-16	G3/4"X14	M16X1.5		O13.3X2.4	18.5	11.5	32	43.5
1BH-12-22	G3/4"X14	M22X1.5		O19.3X2.4	18.5	13	32	45
1BH-12-27	G3/4"X14	M27X2		O23.5X3.0	18.5	16	32	45.5
1BH-16-27	G1"X11	M27X2		O23.5X3.0	20.5	16	41	49
1BH-16-33	G1"X11	M33X2		O29.5X3.0	20.5	16	41	49.5
1BH-20-42	G1.1/4"X11	M42X2		O38.5X3.0	20.5	16	50	51.5
1BH-24-48	G1.1/2"X11	M48X2		O44.5X3.0	23	17.5	55	55.5

注:可与ISO 9974-1油口相配, 去掉挡圈与ISO6149-1油口相配。Note: fit for ISO 9974-1 port or ISO 6149-1 port when useless of retaining ring.

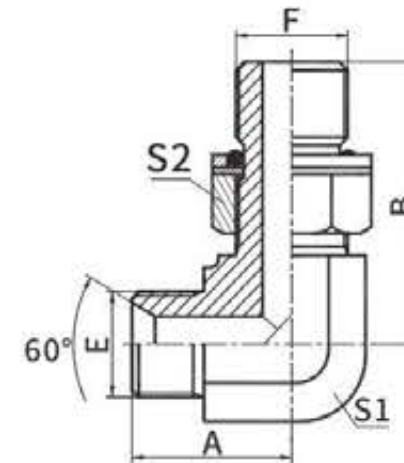
1BH9-OG

90° 弯英管外螺纹60° 内锥/公制外螺纹轻系列ISO 6149-3
 90° ELBOW BSP MALE60° SEAT/
 METRIC MALE L-SERIES ISO 6149-3

代号 PART NO.	螺纹 THREAD		O形圈 O-RING	尺寸 DIMENSIONS				
	E	F		F端	A	B	S1	S2
1BH9-02-10OG	G1/8"X28	M10X1		O08.1X1.6	20	26.5	11	14
1BH9-02-12OG	G1/8"X28	M12X1.5		O09.3X2.4	20	30.5	11	17
1BH9-04-12OG	G1/4"X19	M12X1.5		O09.3X2.4	24.5	32	14	17
1BH9-04-14OG	G1/4"X19	M14X1.5		O11.3X2.4	24.5	32.5	14	19
1BH9-04-16OG	G1/4"X19	M16X1.5		O13.3X2.4	26.5	34.8	16	22
1BH9-06-14OG	G3/8"X19	M14X1.5		O11.3X2.4	27.5	34	16	19
1BH9-06-16OG	G3/8"X19	M16X1.5		O13.3X2.4	27.5	34.8	16	22
1BH9-06-18OG	G3/8"X19	M18X1.5		O15.3X2.4	28.5	37	19	24
1BH9-08-18OG	G1/2"X14	M18X1.5		O15.3X2.4	34.5	39.5	22	24
1BH9-08-22OG	G1/2"X14	M22X1.5		O19.3X2.4	34.5	40.2	22	27
1BH9-10-22OG	G5/8"X14	M22X1.5		O19.3X2.4	35	40.2	22	27
1BH9-12-22OG	G3/4"X14	M22X1.5		O19.3X2.4	40	43.5	27	27
1BH9-12-27OG	G3/4"X14	M27X2		O23.5X3.0	40	48.5	27	32
1BH9-16-27OG	G1"X11	M27X2		O23.5X3.0	46	52	33	32
1BH9-16-33OG	G1"X11	M33X2		O29.5X3.0	34.5	41	33	41
1BH9-20-42OG	G1.1/4"X11	M42X2		O38.5X3.0	50.5	57.2	41	50
1BH9-24-48OG	G1.1/2"X11	M48X2		O44.5X3.0	57.5	62.5	48	55

注:可与ISO 9974-1油口相配, 去掉挡圈与ISO6149-1油口相配。Note: fit for ISO 9974-1 port or ISO 6149-1 port when useless of retaining ring.

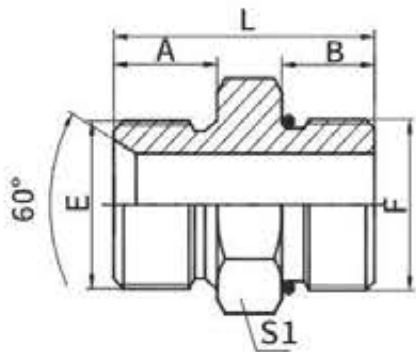

1BO

英管外螺纹60°内锥或六角端面用组合垫密封/
美制SAE外螺纹带O形圈轻系列ISO 11926-3
BSP MALE DOUBLE USE FOR 60°SEAT OR BONDED
SEAL / SAE O-RING BOSS L-SERIES ISO 11926-3

代号 PART NO.	螺纹 THREAD		O形圈 O-RING		尺寸 DIMENSIONS				
	E	F		F端	A	B	L	S1	
1BO-04	G1/4"X19	7/16"X20		O904	12	9.1	29.5	19	
1BO-04-05	G1/4"X19	1/2"X20		O905	12	9.1	29.5	19	
1BO-04-06	G1/4"X19	9/16"X18		O906	12	9.9	32	19	
1BO-04-08	G1/4"X19	3/4"X16		O908	12	11.1	31	22	
1BO-06	G3/8"X19	9/16"X18		O906	13.5	9.9	33.5	22	
1BO-06-04	G3/8"X19	7/16"X20		O904	13.5	9.1	33	22	
1BO-06-08	G3/8"X19	3/4"X16		O908	13.5	11.1	36	24	
1BO-06-10	G3/8"X19	7/8"X14		O910	13.5	12.7	39.5	27	
1BO-08	G1/2"X14	3/4"X16		O908	16	11.1	38	27	
1BO-08-06	G1/2"X14	9/16"X18		O906	16	9.9	36	27	
1BO-08-10	G1/2"X14	7/8"X14		O910	16	12.7	42	27	
1BO-08-12	G1/2"X14	1.1/16"X12		O912	16	15.1	42.5	36	
1BO-10	G5/8"X14	7/8"X14		O910	17.5	12.7	43.5	30	
1BO-10-08	G5/8"X14	3/4"X16		O908	17.5	11.1	41.5	30	
1BO-10-12	G5/8"X14	1.1/16"X12		O912	17.5	15.1	47	34	
1BO-12	G3/4"X14	1.1/16"X12		O912	18.5	15.1	48	34	
1BO-12-08	G3/4"X14	3/4"X16		O908	18.5	11.1	40.5	32	
1BO-12-10	G3/4"X14	7/8"X14		O910	18.5	12.7	45.5	32	
1BO-12-14	G3/4"X14	1.3/16"X12		O914	18.5	15.1	48	38	
1BO-12-16	G3/4"X14	1.5/16"X12		O916	18.5	15.1	50.7	41	
1BO-16	G1"X11	1.5/16"X12		O916	20.5	15.1	52.6	41	
1BO-16-10	G1"X11	7/8"X14		O910	20.5	12.7	49.5	41	
1BO-16-12	G1"X11	1.1/16"X12		O912	20.5	15.1	52	41	
1BO-16-14	G1"X11	1.3/16"X12		O914	20.5	15.1	52	41	
1BO-16-20	G1"X11	1.5/8"X12		O920	20.5	15.1	54.7	50	
1BO-20	G1.1/4"X11	1.5/8"X12		O920	20.5	15.1	54.7	50	
1BO-20-16	G1.1/4"X11	1.5/16"X12		O916	20.5	15.1	54.7	50	
1BO-24	G1.1/2"X11	1.7/8"X12		O924	23	15.1	57	55	

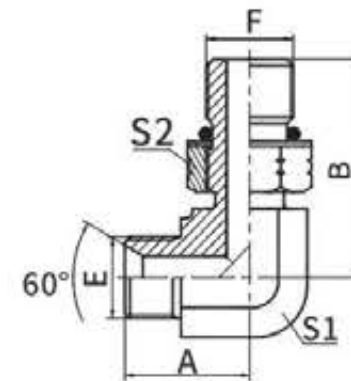

1BO-OG

90° 英管外螺纹60° 内锥/美制SAE外螺纹O形圈
90° BSP MALE 60° SEAT/SAE O-RING BOSS

代号 PART NO.	螺纹 THREAD		O形圈 O-RING		尺寸 DIMENSIONS				
	E	F		F端	A	B	S1	S2	
1BO9-02-04OG	G1/8"X28	7/16"X20		O904	19.8	27.2	11	17	
1BO9-02-05OG	G1/8"X28	1/2"X20		O905	22.3	30	14	17	
1BO9-04OG	G1/4"X19	7/16"X20		O904	25	30.5	14	17	
1BO9-04-05OG	G1/4"X19	1/2"X20		O905	25	29.9	14	17	
1BO9-04-06OG	G1/4"X19	9/16"X18		O906	24.5	31.8	14	19	
1BO9-04-08OG	G1/4"X19	3/4"X16		O908	27.5	37.5	19	24	
1BO9-06-04OG	G3/8"X19	7/16"X20		O904	27.5	31.5	16	17	
1BO9-06OG	G3/8"X19	9/16"X18		O906	27.5	33.3	16	19	
1BO9-06-08OG	G3/8"X19	3/4"X16		O908	28.5	37.5	19	24	
1BO9-06-10OG	G3/8"X19	7/8"X14		O910	31	44	22	27	
1BO9-08OG	G1/2"X14	3/4"X16		O908	34.5	40	22	24	
1BO9-08-10OG	G1/2"X14	7/8"X14		O910	34.5	44	22	27	
1BO9-08-12OG	G1/2"X14	1.1/16"X12		O912	37.5	51	27	32	
1BO9-10OG	G5/8"X14	7/8"X14		O908	35	44	22	27	
1BO9-12OG	G3/4"X14	1.1/16"X12		O912	40	51	27	32	
1BO9-12-08OG	G3/4"X14	3/4"X16		O908	40	43	27	24	
1BO9-12-10OG	G3/4"X14	7/8"X14		O910	40	47	27	27	
1BO9-12-16OG	G3/4"X14	1.5/16"X12		O916	41	54.5	33	41	
1BO9-16OG	G1"X11	1.5/16"X12		O916	46	54.5	33	41	
1BO9-16-12OG	G1"X11	1.1/16"X12		O912	46	54.5	33	32	
1BO9-16-20OG	G1"X11	1.5/8"X12		O920	50.5	59.5	41	50	
1BO9-20OG	G1.1/4"X11	1.5/8"X12		O920	50.5	59.5	41	50	
1BO9-20-16OG	G1.1/4"X11	1.5/16"X12		O916	50.5	59.5	41	41	
1BO9-20-24OG	G1.1/4"X11	1.7/8"X12		O924	54.5	63	48	55	
1BO9-24OG	G1.1/2"X11	1.7/8"X12		O924	57.5	63	48	55	

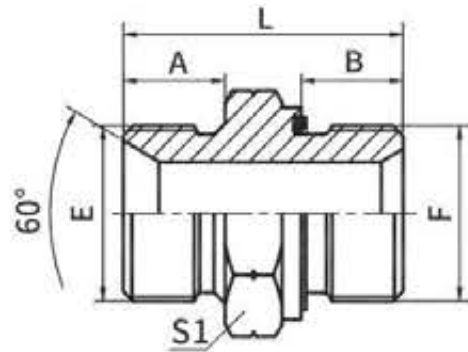
1B-WD

英管外螺纹60°内锥或六角端面用组合垫密封/
 英管外螺纹胶垫密封
 BSP MALE DOUBLE USE FOR 60°SEAT OR
 BONDED SEAL / BSP MALE CAPTIVE SEAL

代号 PART NO.	螺纹 THREAD		胶垫 CAPTIVE	F端	尺寸 DIMENSIONS			
	E	F			A	B	L	S1
1B-04WD	G1/4"X19	G1/4"X19		WD-B04	12	12	32	19
1B-04-06WD	G1/4"X19	G3/8"X19		WD-B06	12	12	34.5	22
1B-04-08WD	G1/4"X19	G1/2"X14		WD-B08	12	14	39	27
1B-06WD	G3/8"X19	G3/8"X19		WD-B06	13.5	12	34	22
1B-06-08WD	G3/8"X19	G1/2"X14		WD-B08	13.5	14	40.5	27
1B-08WD	G1/2"X14	G1/2"X14		WD-B08	16	14	43	27
1B-08-12WD	G1/2"X14	G3/4"X14		WD-B12	16	16	46	32
1B-12WD	G3/4"X14	G3/4"X14		WD-B12	18.5	16	46.5	32
1B-12-16WD	G3/4"X14	G1"X11		WD-B16	18.5	18	52.5	41
1B-16WD	G1"X11	G1"X11		WD-B16	20.5	18	54.5	41
1B-16-20WD	G1"X11	G1.1/4"X11		WD-B20	20.5	20	58.5	50
1B-16-24WD	G1"X11	G1.1/2"X11		WD-B24	20.5	22	60.5	55
1B-20WD	G1.1/4"X11	G1.1/4"X11		WD-B20	20.5	20	58.5	50
1B-20-16WD	G1.1/4"X11	G1"X11		WD-B16	20.5	18	56.5	50
1B-20-24WD	G1.1/4"X11	G1.1/2"X11		WD-B24	20.5	22	60.5	55
1B-24WD	G1.1/2"X11	G1.1/2"X11		WD-B24	23	22	63	55
1B-32WD	G2"X11	G2"X11		WD-B32	25.5	24	72.5	70

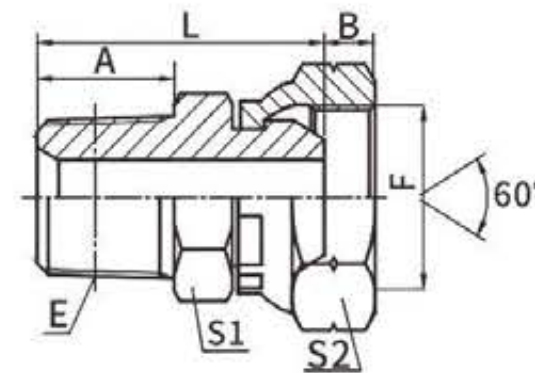
2NB

布锥管外螺纹/英管内螺纹60° 外锥
 NPT MALE/ BSP FEMALE 60° CONE

代号 PART NO.	螺纹 THREAD		尺寸 DIMENSIONS				
	E	F	A	B	L	S1	S2
2NB-02	Z1/8"X27	G1/8"X28	10.5	5.5	25.5	12	14
2NB-02-04	Z1/8"X27	G1/4"X19	10.5	5.5	27	14	19
2NB-04	Z1/4"X18	G1/4"X19	15	5.5	31	17	19
2NB-04-06	Z1/4"X18	G3/8"X19	15	6.3	32.5	17	22
2NB-04-08	Z1/4"X18	G1/2"X14	15	7.5	35	19	27
2NB-06	Z3/8"X18	G3/8"X19	16	6.3	33.5	19	22
2NB-06-08	Z3/8"X18	G1/2"X14	16	7.5	36	19	27
2NB-08	Z1/2"X14	G1/2"X14	19.5	7.5	41	22	27
2NB-08-06	Z1/2"X14	G3/8"X19	19.5	6.3	39.5	24	24
2NB-08-12	Z1/2"X14	G3/4"X14	19.5	10.9	44.5	27	32
2NB-12	Z3/4"X14	G3/4"X14	19.5	10.9	44.5	30	32
2NB-12-16	Z3/4"X14	G1"X11	19.5	11.7	46.5	32	41
2NB-16	Z1"X11.5	G1"X11	25.5	11.7	52.5	36	41
2NB-16-20	Z1"X11.5	G1.1/4"X11	25.5	11	59.5	41	50
2NB-20	Z1.1/4"X11.5	G1.1/4"X11	26.5	11	60.4	46	50
2NB-24	Z1.1/2"X11.5	G1.1/2"X11	27.5	13	62	50	55
2NB-32	Z2"X11.5	G2"X11	27.5	20	65.4	55	70

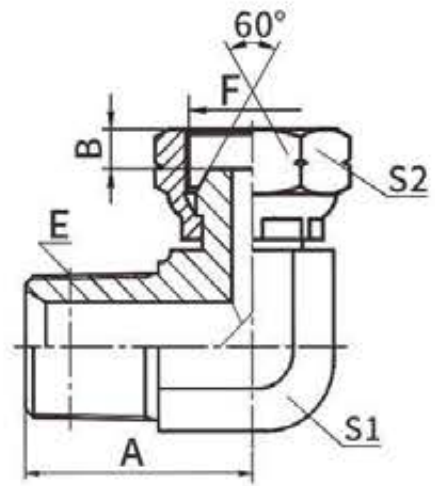
2NB9

90° 弯布锥管外螺纹/英管内螺纹60° 外锥
 90° ELBOW NPT MALE / BSP FEMALE 60° CONE

代号 PART NO.	螺纹 THREAD		尺寸 DIMENSIONS			
	E	F	A	B	S1	S2
2NB9-02	Z1/8"X27	G1/8"X28	21	5.5	11	14
2NB9-04	Z1/4"X18	G1/4"X19	25.5	5.5	14	19
2NB9-04-06	Z1/4"X18	G3/8"X19	25.5	6.3	14	22
2NB9-06	Z3/8"X18	G3/8"X19	31	6.3	19	22
2NB9-06-04	Z3/8"X18	G1/4"X19	31	5.5	19	19
2NB9-08	Z1/2"X14	G1/2"X14	37.3	7.5	22	27
2NB9-08-06	Z1/2"X14	G3/8"X19	36.7	6.3	22	22
2NB9-12	Z3/4"X14	G3/4"X14	43.5	10.9	27	32
2NB9-12-08	Z3/4"X14	G1/2"X14	45	7.5	27	27
2NB9-12-16	Z3/4"X14	G1"X11	45	11.7	30	41
2NB9-16	Z1"X11.5	G1"X11	50	11.7	33	41
2NB9-16-12	Z1"X11.5	G3/4"X14	50	10.9	33	32
2NB9-20	Z1.1/4"X11.5	G1.1/4"X11	54.5	11	41	50
2NB9-24	Z1.1/2"X11.5	G1.1/2"X11	59	13	48	55
2NB9-32	Z2"X11.5	G2"X11	73.5	16	63	70

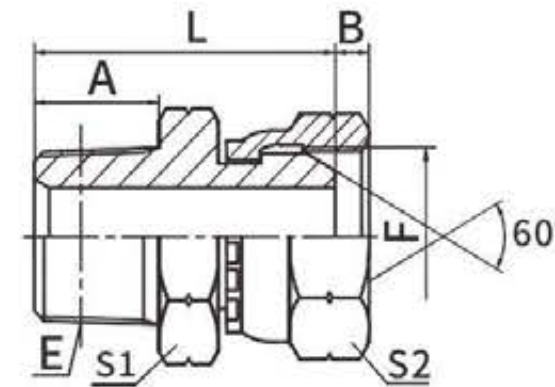
2TB-SP

英锥管外螺纹/英管内螺纹60° 外锥
 BSPT MALE / BSP FEMALE 60° CONE

代号 PART NO.	螺纹 THREAD		尺寸 DIMENSIONS				
	E	F	A	B	L	S1	S2
2TB-02SP	R1/8"X28	G1/8"X28	10	5.5	25	12	14
2TB-04SP	R1/4"X19	G1/4"X19	14.5	5.5	31.5	17	19
2TB-06SP	R3/8"X19	G3/8"X19	15	6.3	33	19	22
2TB-06-04SP	R3/8"X19	G1/4"X19	15	5.5	32	19	19
2TB-06-08SP	R3/8"X19	G1/2"X14	15	7.5	35	19	27
2TB-08SP	R1/2"X14	G1/2"X14	20	7.5	42	22	27
2TB-08-12SP	R1/2"X14	G3/4"X14	20	10.9	45	27	32
2TB-12SP	R3/4"X14	G3/4"X14	20	10.9	45	30	32
2TB-12-08SP	R3/4"X14	G1/2"X14	20	7.5	44	30	27
2TB-12-16SP	R3/4"X14	G1"X11	20	11.7	47	32	41
2TB-16SP	R1"X11	G1"X11	25.5	11.7	52.5	36	41
2TB-16-12SP	R1"X11	G3/4"X14	25.5	10.9	51.5	36	32
2TB-20-16SP	R1.1/4"X11	G1"X11	26.5	11.7	55.5	46	41
2TB-20SP	R1.1/4"X11	G1.1/4"X11	26.5	11	59	46	50
2TB-24SP	R1.1/2"X11	G1.1/2"X11	26.5	13	61.5	50	55
2TB-32SP	R2"X11	G2"X11	30	16	68	65	70

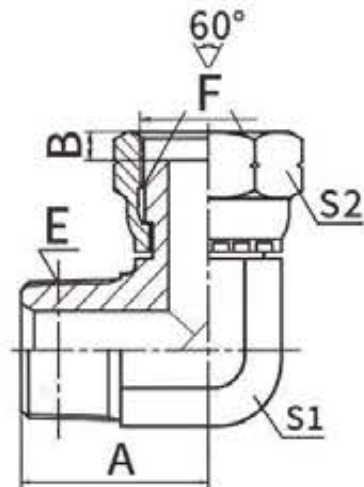

2TB9-SP

90° 弯英锥管外螺纹/英管内螺纹60° 外锥
90° ELBOW BSPT MALE / BSP FEMALE 60° CONE

代号 PART NO.	螺纹 THREAD		尺寸 DIMENSIONS			
	E	F	A	B	S1	S2
2TB9-02SP	R1/8"X28	G1/8"X28	21	5.5	11	14
2TB9-04SP	R1/4"X19	G1/4"X19	25.5	5.5	14	19
2TB9-06SP	R3/8"X19	G3/8"X19	28.5	6.3	16	22
2TB9-06-08SP	R3/8"X19	G1/2"X14	31	7.5	19	27
2TB9-08-06SP	R1/2"X14	G3/8"X19	36	6.3	22	22
2TB9-08SP	R1/2"X14	G1/2"X14	36	7.5	22	27
2TB9-08-12SP	R1/2"X14	G3/4"X14	37	10.9	24	32
2TB9-12-08SP	R3/4"X14	G1/2"X14	43.5	7.5	27	27
2TB9-12SP	R3/4"X14	G3/4"X14	43.5	10.9	27	32
2TB9-16SP	R1"X11	G1"X11	50	11.7	33	41
2TB9-20SP	R1.1/4"X11	G1.1/4"X11	58	11	41	50
2TB9-24SP	R1.1/2"X11	G1.1/2"X11	62.5	13	48	55

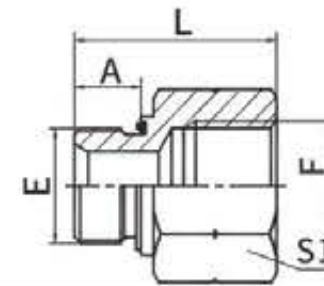

5B-WD

英管外螺纹胶垫密封/英管内螺纹ISO 1179
BSP MALE CAPTIVE SEAL /BSP FEMALE ISO 1179

代号 PART NO.	螺纹 THREAD		胶垫 CAPTIVE		尺寸 DIMENSIONS			
	E	F	E端		A	L	S1	
5B-02-04WD	G1/8"X28	G1/4"X19	WD-B02		8	31	19	
5B-02-06WD	G1/8"X28	G3/8"X19	WD-B02		8	32.5	22	
5B-04-02WD	G1/4"X19	G1/8"X28	WD-B04		12	29	19	
5B-04-06WD	G1/4"X19	G3/8"X19	WD-B04		12	36	22	
5B-04-08WD	G1/4"X19	G1/2"X14	WD-B04		12	40	27	
5B-04-12WD	G1/4"X19	G3/4"X14	WD-B04		12	43	36	
5B-06-02WD	G3/8"X19	G1/8"X28	WD-B06		12	22.5	22	
5B-06-04WD	G3/8"X19	G1/4"X19	WD-B06		12	36	22	
5B-06-08WD	G3/8"X19	G1/2"X14	WD-B06		12	41	27	
5B-06-12WD	G3/8"X19	G3/4"X14	WD-B06		12	44	36	
5B-08-02WD	G1/2"X14	G1/8"X28	WD-B08		14	24	27	
5B-08-04WD	G1/2"X14	G1/4"X19	WD-B08		14	24	27	
5B-08-06WD	G1/2"X14	G3/8"X19	WD-B08		14	37	27	
5B-08-12WD	G1/2"X14	G3/4"X14	WD-B08		14	46	36	
5B-08-16WD	G1/2"X14	G1"X11	WD-B08		14	49	41	
5B-08-20WD	G1/2"X14	G1.1/4"X11	WD-B08		14	53	50	
5B-12-04WD	G3/4"X14	G1/4"X19	WD-B12		16	26	32	
5B-12-06WD	G3/4"X14	G3/8"X19	WD-B12		16	26	32	
5B-12-08WD	G3/4"X14	G1/2"X14	WD-B12		16	43	32	
5B-12-16WD	G3/4"X14	G1"X11	WD-B12		16	51	41	
5B-12-20WD	G3/4"X14	G1.1/4"X11	WD-B12		16	55	50	
5B-12-24WD	G3/4"X14	G1.1/2"X11	WD-B12		16	57	55	
5B-16-04WD	G1"X11	G1/4"X19	WD-B16		18	29	41	
5B-16-06WD	G1"X11	G3/8"X19	WD-B16		18	29	41	
5B-16-08WD	G1"X11	G1/2"X14	WD-B16		18	29	41	
5B-16-12WD	G1"X11	G3/4"X14	WD-B16		18	49	41	
5B-16-20WD	G1"X11	G1.1/4"X11	WD-B16		18	57	50	
5B-16-24WD	G1"X11	G1.1/2"X11	WD-B16		18	59	55	
5B-20-08WD	G1.1/4"X11	G1/2"X14	WD-B20		20	32	50	
5B-20-12WD	G1.1/4"X11	G3/4"X14	WD-B20		20	32	50	
5B-20-16WD	G1.1/4"X11	G1"X11	WD-B20		20	52	50	
5B-20-24WD	G1.1/4"X11	G1.1/2"X11	WD-B20		20	60	55	
5B-20-32WD	G1.1/4"X11	G2"X11	WD-B20		20	64	70	
5B-24-08WD	G1.1/2"X11	G1/2"X14	WD-B24		22	36	55	
5B-24-12WD	G1.1/2"X11	G3/4"X14	WD-B24		22	36	55	
5B-24-16WD	G1.1/2"X11	G1"X11	WD-B24		22	36	55	
5B-24-20WD	G1.1/2"X11	G1.1/4"X11	WD-B24		22	58	55	
5B-24-32WD	G1.1/2"X11	G2"X11	WD-B24		22	66	70	
5B-32-08WD	G2"X11	G1/2"X14	WD-B32		24	45	70	
5B-32-12WD	G2"X11	G3/4"X14	WD-B32		24	45	70	
5B-32-16WD	G2"X11	G1"X11	WD-B32		24	45	70	
5B-32-20WD	G2"X11	G1.1/4"X11	WD-B32		24	45	70	
5B-32-24WD	G2"X11	G1.1/2"X11	WD-B32		24	65	70	

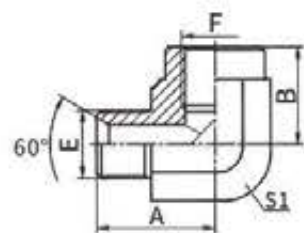
5B9

90° 弯英管外螺纹60° 内锥/英管内螺纹ISO 1179
 90° ELBOW BSP MALE 60° SEAT/BSP FEMALE ISO 1179

代号 PART NO.	螺纹 THREAD		尺寸 DIMENSIONS		
	E	F	A	B	S1
5B9-02	G1/8"X28	G1/8"X28	22.5	20	16
5B9-04	G1/4"X19	G1/4"X19	25.5	22	19
5B9-06	G3/8"X19	G3/8"X19	30.5	26	24
5B9-08	G1/2"X14	G1/2"X14	39	31	30
5B9-12	G3/4"X14	G3/4"X14	43.5	37	33
5B9-16	G1"X11	G1"X11	50.5	43	41
5B9-20	G1.1/4"X11	G1.1/4"X11	55	46	50

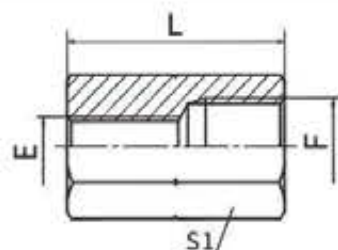
7B

英管内螺纹ISO 1179
 BSP FEMALE ISO 1179

代号 PART NO.	螺纹 THREAD		尺寸 DIMENSIONS	
	E	F	L	S1
7B-02	G1/8"X28	G1/8"X28	22	14
7B-02-04	G1/8"X28	G1/4"X19	24	19
7B-04	G1/4"X19	G1/4"X19	24	19
7B-04-06	G1/4"X19	G3/8"X19	29	22
7B-06	G3/8"X19	G3/8"X19	26	22
7B-08	G1/2"X14	G1/2"X14	32	27
7B-08-10	G1/2"X14	G5/8"X14	36	30
7B-10	G5/8"X14	G5/8"X14	36	30
7B-12	G3/4"X14	G3/4"X14	36	32
7B-12-16	G3/4"X14	G1"X11	43	41
7B-16	G1"X11	G1"X11	40	41
7B-16-20	G1"X11	G1.1/4"X11	46	50
7B-20	G1.1/4"X11	G1.1/4"X11	44	50
7B-20-24	G1.1/4"X11	G1.1/2"X11	48	55
7B-24	G1.1/2"X11	G1.1/2"X11	45	55
7B-24-32	G1.1/2"X11	G2"X11	56	70
7B-32	G2"X11	G2"X11	54	70

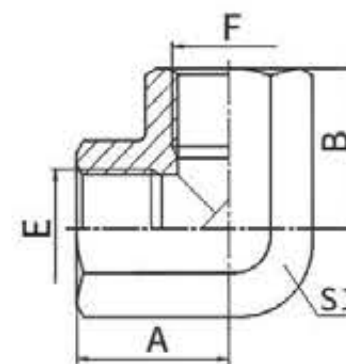
7B9-PK

90° 英管内螺纹ISO 1179
 90° BSP FEMALE ISO 1179

代号 PART NO.	螺纹 THREAD		尺寸 DIMENSIONS		
	E	F	A	B	S1
7B9-02PK	G1/8"X28	G1/8"X28	20	20	16
7B9-04PK	G1/4"X19	G1/4"X19	22.5	22.5	19
7B9-06PK	G3/8"X19	G3/8"X19	26	26	24
7B9-08PK	G1/2"X14	G1/2"X14	31	31	27
7B9-12PK	G3/4"X14	G3/4"X14	34	34	33
7B9-16PK	G1"X11	G1"X11	42	42	41
7B9-20PK	G1.1/4"X11	G1.1/4"X11	48	48	50
7B9-24PK	G1.1/2"X11	G1.1/2"X11	53	53	60
7B9-32PK	G2"X11	G2"X11	62	62	70

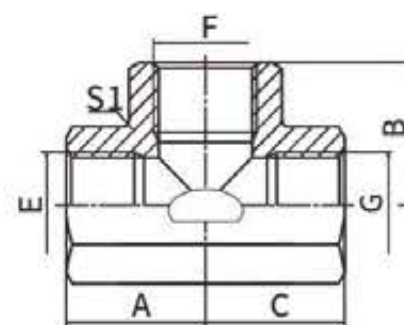
GB-PK

英管内螺纹ISO 1179三通
 BSP FEMALE ISO 1179 TEE

代号 PART NO.	螺纹 THREAD			尺寸 DIMENSIONS			
	E	F	G	A	B	C	S1
GB-02PK	G1/8"X28	G1/8"X28	G1/8"X28	20	20	20	16
GB-04PK	G1/4"X19	G1/4"X19	G1/4"X19	22.5	22.5	22.5	19
GB-06PK	G3/8"X19	G3/8"X19	G3/8"X19	26	26	26	24
GB-08PK	G1/2"X14	G1/2"X14	G1/2"X14	31	31	31	27
GB-12PK	G3/4"X14	G3/4"X14	G3/4"X14	34	34	34	33
GB-16PK	G1"X11	G1"X11	G1"X11	42	42	42	41
GB-20PK	G1.1/4"X11	G1.1/4"X11	G1.1/4"X11	48	48	48	50
GB-24PK	G1.1/2"X11	G1.1/2"X11	G1.1/2"X11	53	53	53	60
GB-32PK	G2"X11	G2"X11	G2"X11	62	62	62	70

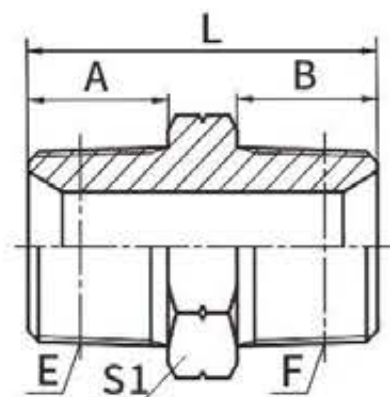
1T-SP

 英锥管外螺纹
 BSPT MALE

代号 PART NO.	螺纹 THREAD		尺寸 DIMENSIONS			
	E	F	A	B	L	S1
1T-02SP	R1/8"X28	R1/8"X28	10	10	26	12
1T-02-04SP	R1/8"X28	R1/4"X19	10	14.5	30.5	14
1T-02-06SP	R1/8"X28	R3/8"X19	10	15	31	17
1T-04SP	R1/4"X19	R1/4"X19	14.5	14.5	34	14
1T-04-06SP	R1/4"X19	R3/8"X19	14.5	15	35	17
1T-06SP	R3/8"X19	R3/8"X19	15	15	36	17
1T-06-08SP	R3/8"X19	R1/2"X14	15	20	43	22
1T-08SP	R1/2"X14	R1/2"X14	20	20	46	22
1T-08-12SP	R1/2"X14	R3/4"X14	20	20	48	27
1T-12SP	R3/4"X14	R3/4"X14	20	20	48	27
1T-12-16SP	R3/4"X14	R1"X11	20	25.5	55.5	36
1T-16SP	R1"X11	R1"X11	25.5	25.5	61	36
1T-16-20SP	R1"X11	R1.1/4"X11	25.5	26.5	64.5	46
1T-20SP	R1.1/4"X11	R1.1/4"X11	26.5	26.5	65.5	46
1T-20-24SP	R1.1/4"X11	R1.1/2"X11	26.5	26.5	67	50
1T-24SP	R1.1/2"X11	R1.1/2"X11	26.5	26.5	67	50
1T-24-32SP	R1.1/2"X11	R2"X11	26.5	30	71.5	65
1T-32SP	R2"X11	R2"X11	30	30	75	65

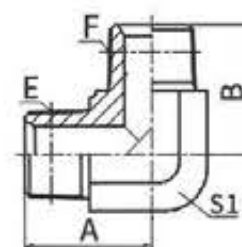
1T9-SP

 90° 弯英锥管外螺纹
 90° ELBOW BSPT MALE

代号 PART NO.	螺纹 THREAD		尺寸 DIMENSIONS		
	E	F	A	B	S1
1T9-02SP	R1/8"X28	R1/8"X28	21	21	11
1T9-02-04SP	R1/8"X28	R1/4"X19	23.5	25.5	14
1T9-04SP	R1/4"X19	R1/4"X19	25.5	25.5	14
1T9-04-06SP	R1/4"X19	R3/8"X19	26.5	28.5	16
1T9-04-08SP	R1/4"X19	R1/2"X14	30.5	36	22
1T9-06SP	R3/8"X19	R3/8"X19	28.5	28.5	17
1T9-06-08SP	R3/8"X19	R1/2"X14	32.5	36	22
1T9-08SP	R1/2"X14	R1/2"X14	36	36	22
1T9-08-12SP	R1/2"X14	R3/4"X14	39.5	43.5	27
1T9-12SP	R3/4"X14	R3/4"X14	43.5	43.5	27
1T9-12-16SP	R3/4"X14	R1"X11	48	50	33
1T9-16SP	R1"X11	R1"X11	50	50	33
1T9-16-20SP	R1"X11	R1.1/4"X11	56.5	57.5	41
1T9-20SP	R1.1/4"X11	R1.1/4"X11	57.5	57.5	41
1T9-24SP	R1.1/2"X11	R1.1/2"X11	62.5	62.5	48
1T9-32SP	R2"X11	R2"X11	68	75	63

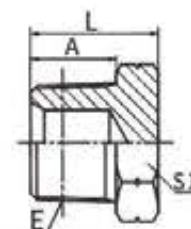
4T-SP

 英锥管外螺纹堵头
 BSPT MALE PLUG

代号 PART NO.	螺纹 THREAD	尺寸 DIMENSIONS		
	E	A	L	S1
4T-02SP	R1/8"X28	10	16	12
4T-04SP	R1/4"X19	14.5	20	14
4T-06SP	R3/8"X19	15	21	17
4T-08SP	R1/2"X14	20	27	22
4T-12SP	R3/4"X14	20	29	27
4T-16SP	R1"X11	25.5	36.5	36
4T-20SP	R1.1/4"X11	26.5	38.5	46
4T-24SP	R1.1/2"X11	26.5	42	50
4T-32SP	R2"X11	30	47	65

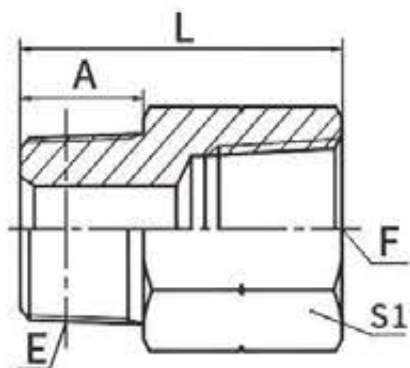
5T-SP

 英锥管外螺纹/英锥管内螺纹
 BBSPT MALE/ BSPT FEMALE

代号 PART NO.	螺纹 THREAD		尺寸 DIMENSIONS		
	E	F	A	L	S1
5T-02-04SP	R1/8"X28	Rc1/4"X19	11	32.5	19
5T-04-02SP	R1/4"X19	Rc1/8"X28	14.5	20.5	14
5T-04SP	R1/4"X19	Rc1/4"X19	14.5	36	19
5T-04-06SP	R1/4"X19	Rc3/8"X19	14.5	38	22
5T-06-02SP	R3/8"X19	Rc1/8"X28	15	23	19
5T-06SP	R3/8"X19	Rc3/8"X19	15	38.5	22
5T-06-08SP	R3/8"X19	Rc1/2"X14	15	44	27
5T-08-04SP	R1/2"X14	Rc1/4"X19	20	30	24
5T-08-06SP	R1/2"X14	Rc3/8"X19	20	30	24
5T-08SP	R1/2"X14	Rc1/2"X14	20	49	27
5T-08-12SP	R1/2"X14	Rc3/4"X14	20	51	36
5T-12-06SP	R3/4"X14	Rc3/8"X19	20	31	30
5T-12-08SP	R3/4"X14	Rc1/2"X14	20	31	30
5T-12SP	R3/4"X14	Rc3/4"X14	20	51	36
5T-12-16SP	R3/4"X14	Rc1"X11	20	56.5	41
5T-16-08SP	R1"X11	Rc1/2"X14	25.5	37	36
5T-16-12SP	R1"X11	Rc3/4"X14	25.5	37	36
5T-16SP	R1"X11	Rc1"X11	25.5	60	41
5T-16-20SP	R1"X11	Rc1.1/4"X11	25.5	64	50
5T-20-12SP	R1.1/4"X11	Rc3/4"X14	26.5	38	46
5T-20-16SP	R1.1/4"X11	Rc1"X11	26.5	38	46
5T-20SP	R1.1/4"X11	Rc1.1/4"X11	26.5	64.5	50
5T-24-16SP	R1.1/2"X11	Rc1"X11	26.5	41	50
5T-24-20SP	R1.1/2"X11	Rc1.1/4"X11	26.5	41	50
5T-32-20SP	R2"X11	Rc1.1/4"X11	30	45	65
5T-32-24SP	R2"X11	Rc1.1/2"X11	30	45	65

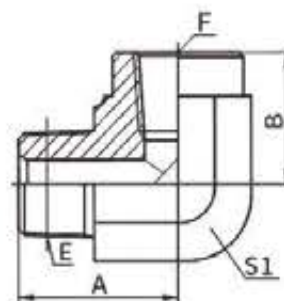
5T9-SP

 90° 弯英锥管外螺纹/英锥管内螺纹
 90° ELBOW BSPT MALE / BSPT FEMALE

代号 PART NO.	螺纹 THREAD		尺寸 DIMENSIONS		
	E	F	A	B	S1
5T9-02SP	R1/8"X28	Rc1/8"X28	24.5	23	16
5T9-04SP	R1/4"X19	Rc1/4"X19	28.5	25	19
5T9-06SP	R3/8"X19	Rc3/8"X19	33.5	25	24
5T9-08SP	R1/2"X14	Rc1/2"X14	40.8	31.5	30
5T9-12SP	R3/4"X14	Rc3/4"X14	47.5	37	33
5T9-16SP	R1"X11	Rc1"X11	56.5	43	41
5T9-20SP	R1.1/4"X11	Rc1.1/4"X11	61	50	48
5T9-24SP	R1.1/2"X11	Rc1.1/2"X11	75	55	63

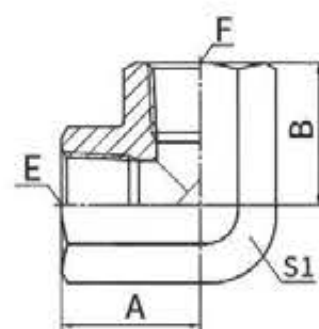

7T9-PK

 90° 弯英锥管内螺纹
 90° ELBOW BSPT FEMALE

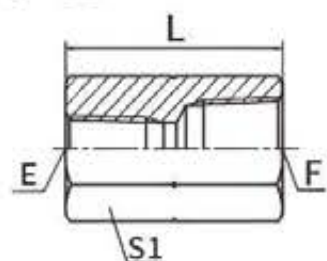
代号 PART NO.	螺纹 THREAD		尺寸 DIMENSIONS		
	E	F	A	B	S1
7T9-02PK	Rc1/8"X28	Rc1/8"X28	20	20	16
7T9-02-04PK	Rc1/8"X28	Rc1/4"X19	20	22.5	19
7T9-04PK	Rc1/4"X19	Rc1/4"X19	22.5	22.5	19
7T9-06PK	Rc3/8"X19	Rc3/8"X19	26	26	24
7T9-08PK	Rc1/2"X14	Rc1/2"X14	31	31	27
7T9-12PK	Rc3/4"X14	Rc3/4"X14	34	34	33
7T9-16PK	Rc1"X11	Rc1"X11	42	42	41
7T9-20PK	Rc1.1/4"X11	Rc1.1/4"X11	48	48	50
7T9-24PK	Rc1.1/2"X11	Rc1.1/2"X11	53	53	60
7T9-32PK	Rc2"X11	Rc2"X11	62	62	70

7T
**英锥管内螺纹
BSPT FEMALE**

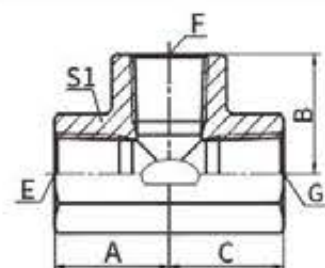
代号 PART NO.	螺纹 THREAD		尺寸 DIMENSIONS	
	E	F	L	S1
7T-02	Rc1/8"X28	Rc1/8"X28	20	14
7T-02-04	Rc1/8"X28	Rc1/4"X19	30	19
7T-04	Rc1/4"X19	Rc1/4"X19	30	19
7T-04-06	Rc1/4"X19	Rc3/8"X19	30	22
7T-04-08	Rc1/4"X19	Rc1/2"X14	40	27
7T-06	Rc3/8"X19	Rc3/8"X19	30	22
7T-06-08	Rc3/8"X19	Rc1/2"X14	40	27
7T-06-12	Rc3/8"X19	Rc3/4"X14	37	36
7T-08	Rc1/2"X14	Rc1/2"X14	40	27
7T-08-12	Rc1/2"X14	Rc3/4"X14	42	36
7T-12	Rc3/4"X14	Rc3/4"X14	42	36
7T-12-16	Rc3/4"X14	Rc1"X11	50	41
7T-16	Rc1"X11	Rc1"X11	50	41
7T-16-20	Rc1"X11	Rc1.1/4"X11	52	50
7T-20	Rc1.1/4"X11	Rc1.1/4"X11	55	50
7T-24	Rc1.1/2"X11	Rc1.1/2"X11	55	55
7T-32	Rc2"X11	Rc2"X11	65	70

GT-PK
**英锥管内螺纹三通
BSPT FEMALE TEE**

代号 PART NO.	螺纹 THREAD			尺寸 DIMENSIONS			
	E	F	G	A	B	C	S1
GT-02PK	Rc1/8"X28	Rc1/8"X28	Rc1/8"X28	20	20	20	16
GT-04PK	Rc1/4"X19	Rc1/4"X19	Rc1/4"X19	22.5	22.5	22.5	19
GT-06PK	Rc3/8"X19	Rc3/8"X19	Rc3/8"X19	26	26	26	24
GT-08PK	Rc1/2"X14	Rc1/2"X14	Rc1/2"X14	31	31	31	27
GT-12PK	Rc3/4"X14	Rc3/4"X14	Rc3/4"X14	34	34	34	33
GT-16PK	Rc1"X11	Rc1"X11	Rc1"X11	42	42	42	41
GT-24PK	Rc1.1/2"X11	Rc1.1/2"X11	Rc1.1/2"X11	53	53	53	60
GT-32PK	Rc2"X11	Rc2"X11	Rc2"X11	62	62	62	70

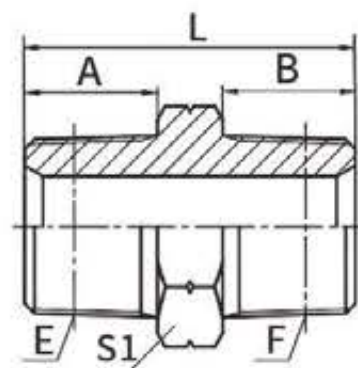
1N
**美制布锥管外螺纹
NPT MALE**

代号 PART NO.	螺纹 THREAD		尺寸 DIMENSIONS			
	E	F	A	B	L	S1
1N-02	Z1/8"X27	Z1/8"X27	10.5	10.5	27	12
1N-02-04	Z1/8"X27	Z1/4"X18	10.5	15	31	17
1N-02-06	Z1/8"X27	Z3/8"X18	10.5	16	32	19
1N-04	Z1/4"X18	Z1/4"X18	15	15	35	17
1N-04-06	Z1/4"X18	Z3/8"X18	15	16	37	19
1N-06	Z3/8"X18	Z3/8"X18	16	16	38	19
1N-06-08	Z3/8"X18	Z1/2"X14	16	19.5	43.5	22
1N-06-12	Z3/8"X18	Z3/4"X14	16	19.5	45.5	27
1N-08	Z1/2"X14	Z1/2"X14	19.5	19.5	47	22
1N-08-12	Z1/2"X14	Z3/4"X14	19.5	19.5	49	27
1N-08-16	Z1/2"X14	Z1"X11.5	19.5	25.5	56	36
1N-12	Z3/4"X14	Z3/4"X14	19.5	19.5	49	27
1N-12-16	Z3/4"X14	Z1"X11.5	19.5	25.5	55	36
1N-12-20	Z3/4"X14	Z1.1/4"X11.5	19.5	26.5	59	46
1N-16	Z1"X11.5	Z1"X11.5	25.5	25.5	61	36
1N-16-20	Z1"X11.5	Z1.1/4"X11.5	25.5	26.5	64	46
1N-16-24	Z1"X11.5	Z1.1/2"X11.5	25.5	27.5	68	50
1N-20	Z1.1/4"X11.5	Z1.1/4"X11.5	26.5	26.5	65	46
1N-20-24	Z1.1/4"X11.5	Z1.1/2"X11.5	26.5	27.5	69	50
1N-24	Z1.1/2"X11.5	Z1.1/2"X11.5	27.5	27.5	69	50
1N-24-32	Z1.1/2"X11.5	Z2"X11.5	27.5	27.5	72	65
1N-32	Z2"X11.5	Z2"X11.5	27.5	27.5	71	65

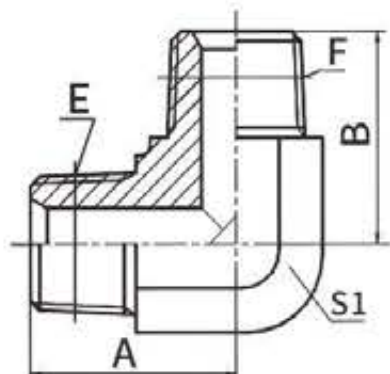
1N9
**90° 弯布锥管外螺纹
90° ELBOW NPT MALE**

代号 PART NO.	螺纹 THREAD		尺寸 DIMENSIONS		
	E	F	A	B	S1
1N9-02	Z1/8"X27	Z1/8"X27	21	21	11
1N9-02-04	Z1/8"X27	Z1/4"X18	23.5	25.5	14
1N9-04	Z1/4"X18	Z1/4"X18	25.5	25.5	14
1N9-04-06	Z1/4"X18	Z3/8"X18	28	31	19
1N9-04-08	Z1/4"X18	Z1/2"X14	30.5	36.5	22
1N9-06	Z3/8"X18	Z3/8"X18	31	31	19
1N9-06-08	Z3/8"X18	Z1/2"X14	33.8	37.3	22
1N9-08	Z1/2"X14	Z1/2"X14	37.3	37.3	22
1N9-08-12	Z1/2"X14	Z3/4"X14	40	44	27
1N9-12	Z3/4"X14	Z3/4"X14	44	44	27
1N9-12-16	Z3/4"X14	Z1"X11.5	46.5	50	33
1N9-16	Z1"X11.5	Z1"X11.5	50	50	33
1N9-20	Z1.1/4"X11.5	Z1.1/4"X11.5	54	54	41
1N9-24	Z1.1/2"X11.5	Z1.1/2"X11.5	63	63	48
1N9-32	Z2"X11.5	Z2"X11.5	68	68	63

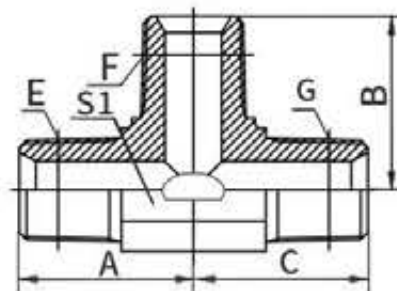
AN
**美制布锥管外螺纹三通
NPT MALE TEE**

代号 PART NO.	螺纹 THREAD			尺寸 DIMENSIONS			
	E	F	G	A	B	C	S1
AN-02	Z1/8"X27	Z1/8"X27	Z1/8"X27	21	21	21	11
AN-04	Z1/4"X18	Z1/4"X18	Z1/4"X18	25.5	25.5	25.5	14
AN-06	Z3/8"X18	Z3/8"X18	Z3/8"X18	31	31	31	19
AN-08	Z1/2"X14	Z1/2"X14	Z1/2"X14	36.7	36.7	36.7	22
AN-12	Z3/4"X14	Z3/4"X14	Z3/4"X14	44	44	44	27
AN-16	Z1"X11.5	Z1"X11.5	Z1"X11.5	50	50	50	33
AN-20	Z1.1/4"X11.5	Z1.1/4"X11.5	Z1.1/4"X11.5	54.5	54.5	54.5	41
AN-24	Z1.1/2"X11.5	Z1.1/2"X11.5	Z1.1/2"X11.5	59.5	59.5	59.5	48

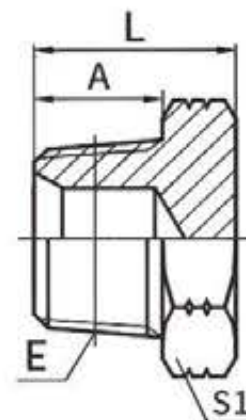

4N
**美制布锥管外螺纹堵头
NPT MALE PLUG**

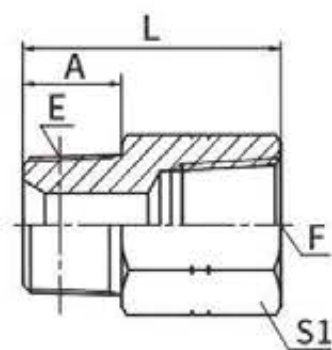
代号 PART NO.	螺纹 THREAD	尺寸 DIMENSIONS		
	E	A	L	S1
4N-02	Z1/8"X27	10.5	16	12
4N-04	Z1/4"X18	15	20	17
4N-06	Z3/8"X18	16	21	19
4N-08	Z1/2"X14	19.5	27	22
4N-12	Z3/4"X14	19.5	29.5	27
4N-16	Z1"X11.5	25.5	36.5	36
4N-20	Z1.1/4"X11.5	26.5	38.5	46
4N-24	Z1.1/2"X11.5	27.5	43	50
4N-32	Z2"X11.5	27.5	43.5	65

5N

 布锥管外螺纹/布锥管内螺纹
 NPT MALE / NPT FEMALE

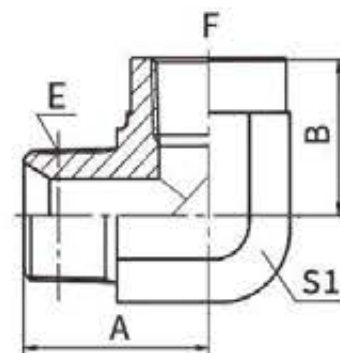
代号 PART NO.	螺纹 THREAD		尺寸 DIMENSIONS		
	E	F	A	L	S1
5N-02	Z1/8"X27	Z1/8"X27	10.5	25.5	17
5N-02-04	Z1/8"X27	Z1/4"X18	10.5	31	19
5N-02-06	Z1/8"X27	Z3/8"X18	11	31	24
5N-04-02	Z1/4"X18	Z1/8"X27	15	22	17
5N-04	Z1/4"X18	Z1/4"X18	15	35.3	19
5N-04-06	Z1/4"X18	Z3/8"X18	15	36.6	24
5N-06-02	Z3/8"X18	Z1/8"X27	16	22	19
5N-06-04	Z3/8"X18	Z1/4"X18	16	22	19
5N-06	Z3/8"X18	Z3/8"X18	16	37.6	24
5N-06-08	Z3/8"X18	Z1/2"X14	17	43.7	30
5N-06-12	Z3/8"X18	Z3/4"X14	17	47	36
5N-08-04	Z1/2"X14	Z1/4"X18	19.5	28	24
5N-08-06	Z1/2"X14	Z3/8"X18	19.5	28.5	24
5N-08	Z1/2"X14	Z1/2"X14	19.5	47.5	30
5N-08-12	Z1/2"X14	Z3/4"X14	19.5	49	36
5N-12-06	Z3/4"X14	Z3/8"X18	19.5	30.5	27
5N-12-08	Z3/4"X14	Z1/2"X14	19.5	30.5	27
5N-12	Z3/4"X14	Z3/4"X14	19.5	49	36
5N-12-16	Z3/4"X14	Z1"X11.5	19.5	55.4	41
5N-16-08	Z1"X11.5	Z1/2"X14	25.5	35.5	36
5N-16-12	Z1"X11.5	Z3/4"X14	25.5	36.5	36
5N-16	Z1"X11.5	Z1"X11.5	25.5	60.7	41
5N-16-20	Z1"X11.5	Z1.1/4"X11.5	25.5	63.5	50
5N-20-12	Z1.1/4"X11.5	Z3/4"X14	26.5	38.5	46
5N-20-16	Z1.1/4"X11.5	Z1"X11.5	26.5	41	46
5N-20	Z1.1/4"X11.5	Z1.1/4"X11.5	26.5	61.5	50
5N-20-24	Z1.1/4"X11.5	Z1.1/2"X11.5	26.5	62.5	60
5N-24-16	Z1.1/2"X11.5	Z1"X11.5	27.5	41.5	50
5N-24-20	Z1.1/2"X11.5	Z1.1/4"X11.5	27.5	41	50
5N-24	Z1.1/2"X11.5	Z1.1/2"X11.5	27.5	62.5	65
5N-24-32	Z1.1/2"X11.5	Z2"X11.5	27.5	66.5	70
5N-32-20	Z2"X11.5	Z1.1/4"X11.5	27.5	44.5	65
5N-32-24	Z2"X11.5	Z1.1/2"X11.5	27.5	45	65
5N-32	Z2"X11.5	Z2"X11.5	27.5	62.5	70

5N9

 90° 弯布锥管外螺纹/布锥管内螺纹
 90° ELBOW NPT MALE / NPT FEMALE

代号 PART NO.	螺纹 THREAD		尺寸 DIMENSIONS		
	E	F	A	B	S1
5N9-02	Z1/8"X27	Z1/8"X27	24.5	17.8	16
5N9-04-02	Z1/4"X18	Z1/8"X27	26.5	16.8	16
5N9-04	Z1/4"X18	Z1/4"X18	28	22.4	19
5N9-04-06	Z1/4"X18	Z3/8"X18	31	25	24
5N9-06-04	Z3/8"X18	Z1/4"X18	31	22.4	19
5N9-06	Z3/8"X18	Z3/8"X18	33.5	25	24
5N9-08	Z1/2"X14	Z1/2"X14	41.2	31.2	30
5N9-12-08	Z3/4"X14	Z1/2"X14	45	31.2	30
5N9-12	Z3/4"X14	Z3/4"X14	45.2	34.5	33
5N9-16	Z1"X11.5	Z1"X11.5	54.5	41.1	41
5N9-20	Z1.1/4"X11.5	Z1.1/4"X11.5	63	43.2	48
5N9-24	Z1.1/2"X11.5	Z1.1/2"X11.5	71.5	52.8	63
5N9-32	Z2"X11.5	Z2"X11.5	73.5	62	65

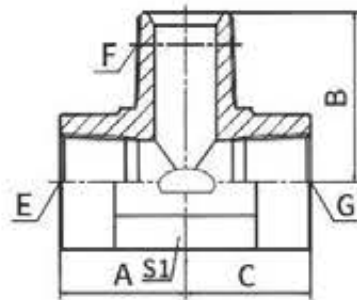
JN

 布锥管内螺纹/布锥管外螺纹三通
NPT FEMALE / NPT MALE BRANCH TEE

代号 PART NO.	螺纹 THREAD			尺寸 DIMENSIONS			
	E	F	G	A	B	C	S1
JN-02	Z1/8"X27	Z1/8"X27	Z1/8"X27	17.8	24.5	17.8	14
JN-04	Z1/4"X18	Z1/4"X18	Z1/4"X18	22.4	28	22.4	19
JN-06	Z3/8"X18	Z3/8"X18	Z3/8"X18	25	33.5	25	24
JN-08	Z1/2"X14	Z1/2"X14	Z1/2"X14	31.2	41.2	31.2	30
JN-12	Z3/4"X14	Z3/4"X14	Z3/4"X14	34.5	45.2	34.5	33
JN-16	Z1"X11.5	Z1"X11.5	Z1"X11.5	41.5	54.5	41.5	41
JN-20	Z1.1/4"X11.5	Z1.1/4"X11.5	Z1.1/4"X11.5	48	58.5	48	48
JN-24	Z1.1/2"X11.5	Z1.1/2"X11.5	Z1.1/2"X11.5	52.8	71.5	52.8	63

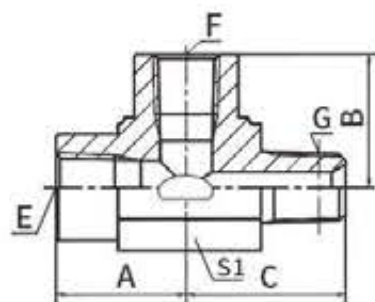
HN

 美制布锥管内螺纹/布锥管外螺纹主支三通
NPT FEMALE / NPT MALE RUN TEE

代号 PART NO.	螺纹 THREAD			尺寸 DIMENSIONS			
	E	F	G	A	B	C	S1
HN-02	Z1/8"X27	Z1/8"X27	Z1/8"X27	20	20	24.5	16
HN-04	Z1/4"X18	Z1/4"X18	Z1/4"X18	25	25	28.5	19
HN-06	Z3/8"X18	Z3/8"X18	Z3/8"X18	27	27	33.5	24
HN-08	Z1/2"X14	Z1/2"X14	Z1/2"X14	35	35	42.5	30
HN-12	Z3/4"X14	Z3/4"X14	Z3/4"X14	37	37	45.2	33
HN-16	Z1"X11.5	Z1"X11.5	Z1"X11.5	44	44	54.5	41
HN-20	Z1.1/4"X11.5	Z1.1/4"X11.5	Z1.1/4"X11.5	48	48	58.5	48
HN-24	Z1.1/2"X11.5	Z1.1/2"X11.5	Z1.1/2"X11.5	52.8	52.8	71.5	63

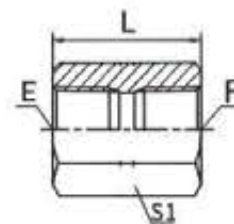
7N

 美制布锥管内螺纹
NPT FEMALE

代号 PART NO.	螺纹 THREAD		尺寸 DIMENSIONS	
	E	F	L	S1
7N-02	Z1/8"X27	Z1/8"X27	24	17
7N-02-04	Z1/8"X27	Z1/4"X18	27	19
7N-02-06	Z1/8"X27	Z3/8"X18	30	22
7N-04	Z1/4"X18	Z1/4"X18	29	19
7N-04-06	Z1/4"X18	Z3/8"X18	31	22
7N-06	Z3/8"X18	Z3/8"X18	29	22
7N-06-08	Z3/8"X18	Z1/2"X14	38	30
7N-06-12	Z3/8"X18	Z3/4"X14	40	36
7N-08	Z1/2"X14	Z1/2"X14	38	30
7N-08-12	Z1/2"X14	Z3/4"X14	43	36
7N-12	Z3/4"X14	Z3/4"X14	39	36
7N-12-16	Z3/4"X14	Z1"X11.5	45.5	41
7N-16	Z1"X11.5	Z1"X11.5	48	41
7N-20	Z1.1/4"X11.5	Z1.1/4"X11.5	49	50
7N-24	Z1.1/2"X11.5	Z1.1/2"X11.5	49	60
7N-32	Z2"X11.5	Z2"X11.5	50	70

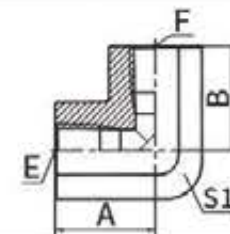
7N9-PK

 90° 弯美制布锥管内螺纹
90° ELBOW NPT FEMALE

代号 PART NO.	螺纹 THREAD		尺寸 DIMENSIONS		
	E	F	A	B	S1
7N9-02PK	Z1/8"X27	Z1/8"X27	20	20	16
7N9-02-04PK	Z1/8"X27	Z1/4"X18	20	22.5	19
7N9-04PK	Z1/4"X18	Z1/4"X18	22.5	22.5	19
7N9-04-06PK	Z1/4"X18	Z3/8"X18	25	26	24
7N9-06PK	Z3/8"X18	Z3/8"X18	26	26	24
7N9-08PK	Z1/2"X14	Z1/2"X14	31	31	27
7N9-08-12PK	Z1/2"X14	Z3/4"X14	34	34	33
7N9-12PK	Z3/4"X14	Z3/4"X14	34	34	33
7N9-12-16PK	Z3/4"X14	Z1"X11.5	42	42	41
7N9-16PK	Z1"X11.5	Z1"X11.5	42	42	41
7N9-20PK	Z1.1/4"X11.5	Z1.1/4"X11.5	48	48	50
7N9-24PK	Z1.1/2"X11.5	Z1.1/2"X11.5	53	53	60
7N9-32PK	Z2"X11.5	Z2"X11.5	62	62	70

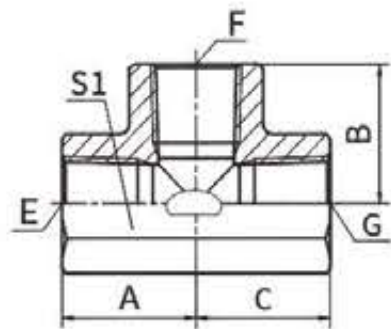

GN-PK

美制布锥管内螺纹三通
NPT FEMALE TEE

代号 PART NO.	螺纹 THREAD			尺寸 DIMENSIONS			
	E	F	G	A	B	C	S1
GN-02PK	Z1/8"X27	Z1/8"X27	Z1/8"X27	20	20	20	16
GN-04PK	Z1/4"X18	Z1/4"X18	Z1/4"X18	22.5	22.5	22.5	19
GN-06PK	Z3/8"X18	Z3/8"X18	Z3/8"X18	26	26	26	24
GN-08PK	Z1/2"X14	Z1/2"X14	Z1/2"X14	31	31	31	27
GN-12PK	Z3/4"X14	Z3/4"X14	Z3/4"X14	34	34	34	33
GN-16PK	Z1"X11.5	Z1"X11.5	Z1"X11.5	42	42	42	41
GN-20PK	Z1.1/4"X11.5	Z1.1/4"X11.5	Z1.1/4"X11.5	48	48	48	50
GN-24PK	Z1.1/2"X11.5	Z1.1/2"X11.5	Z1.1/2"X11.5	53	53	53	60
GN-32PK	Z2"X11.5	Z2"X11.5	Z2"X11.5	62	62	62	70

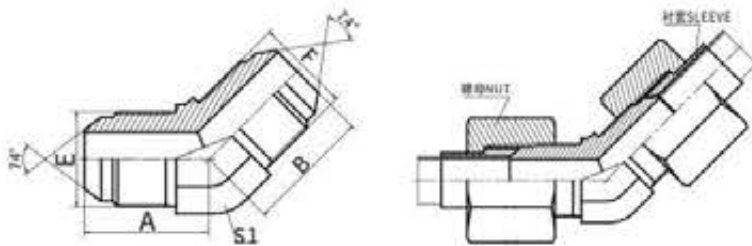

1J4

45° 弯美制JIC外螺纹74° 外锥
45° ELBOW JIC MALE 74° CONE

代号 PART NO.	螺纹 THREAD		尺寸 DIMENSIONS			
	E	F	A	B	S1	
1J4-04	7/16"X20	7/16"X20	21.5	21.5	11	
1J4-05	1/2"X20	1/2"X20	23	23	14	
1J4-06	9/16"X18	9/16"X18	22.8	22.8	14	
1J4-08	3/4"X16	3/4"X16	26.8	26.8	19	
1J4-10	7/8"X14	7/8"X14	31	31	22	
1J4-12	1.1/16"X12	1.1/16"X12	35.5	35.5	27	
1J4-16	1.5/16"X12	1.5/16"X12	38.5	38.5	33	

注:螺母及衬套需另行订货。管子直径D为公制时, 配用螺母及衬套分别选用NB200、NB500。管子直径为英制时, 配用螺母及衬套分别选用NB200、NB300。Note : Nut and sleeve should be ordered separately.The nut NB200 and sleeve NB500 is suitable for metric tube,the nut NB200 and sleeve NB300 is suitable for inch tube.

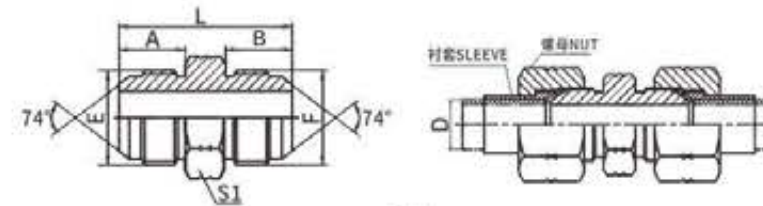

1J

美制JIC外螺纹74° 外锥
JIC MALE 74° CONE

代号 PART NO.	螺纹 THREAD		尺寸 DIMENSIONS			
	E	F	A	B	L	S1
1J-02	5/16"X24	5/16"X24	11.4	11.4	29	12
1J-02-03	5/16"X24	3/8"X24	11.4	12.2	29.5	12
1J-03	3/8"X24	3/8"X24	12.2	12.2	30.5	12
1J-04	7/16"X20	7/16"X20	14	14	34	12
1J-04-05	7/16"X20	1/2"X20	14	14	34	14
1J-04-08	7/16"X20	3/4"X16	14	16.7	38.5	22
1J-05	1/2"X20	1/2"X20	14	14	34	14
1J-05-06	1/2"X20	9/16"X18	14	14.1	34	17
1J-05-08	1/2"X20	3/4"X16	14	16.7	38.5	22
1J-05-10	1/2"X20	7/8"X14	14	19.3	41	24
1J-06	9/16"X18	9/16"X18	14.4	14.1	34.2	17
1J-06-08	9/16"X18	3/4"X16	14.1	16.7	38.5	22
1J-06-10	9/16"X18	7/8"X14	14.1	19.3	41.5	24
1J-06-12	9/16"X18	1.1/16"X12	14.1	21.9	46	30
1J-08	3/4"X16	3/4"X16	16.7	16.7	42	22
1J-08-10	3/4"X16	7/8"X14	16.7	19.3	44	24
1J-08-12	3/4"X16	1.1/16"X12	16.7	21.9	48.5	30
1J-08-16	3/4"X16	1.5/16"X12	16.7	23.1	51	36
1J-10	7/8"X14	7/8"X14	19.3	19.3	46.5	24
1J-10-12	7/8"X14	1.1/16"X12	19.3	21.9	51	30
1J-10-16	7/8"X14	1.5/16"X12	19.3	23.1	53.5	36
1J-12	1.1/16"X12	1.1/16"X12	21.9	21.9	54	30
1J-12-14	1.1/16"X12	1.3/16"X12	21.9	22.6	55.5	32
1J-12-16	1.1/16"X12	1.5/16"X12	21.9	23.1	56	36
1J-14	1.3/16"X12	1.3/16"X12	22.6	22.6	56	32
1J-14-16	1.3/16"X12	1.5/16"X12	22.6	23.1	56.5	36
1J-16	1.5/16"X12	1.5/16"X12	23.1	23.1	57	36
1J-16-20	1.5/16"X12	1.5/8"X12	23.1	24.3	60.5	46
1J-16-24	1.5/16"X12	1.7/8"X12	23.1	27.5	65.5	50
1J-20	1.5/8"X12	1.5/8"X12	24.3	24.3	62	46
1J-20-24	1.5/8"X12	1.7/8"X12	24.3	27.5	67	50
1J-20-32	1.5/8"X12	2.1/2"X12	24.3	33.9	75	65
1J-24	1.7/8"X12	1.7/8"X12	27.5	27.5	70	50
1J-24-32	1.7/8"X12	2.1/2"X12	27.5	33.9	78.5	65
1J-32	2.1/2"X12	2.1/2"X12	33.9	33.9	85	65

注:螺母及衬套需另行订货。管子直径D为公制时, 配用螺母及衬套分别选用NB200、NB500。管子直径为英制时, 配用螺母及衬套分别选用NB200、NB300。Note: Nut and sleeve should be ordered separately.The nut NB200 and sleeve NB500 is suitable for metric tube,the nut NB200 and sleeve NB300 is suitable for inch tube.

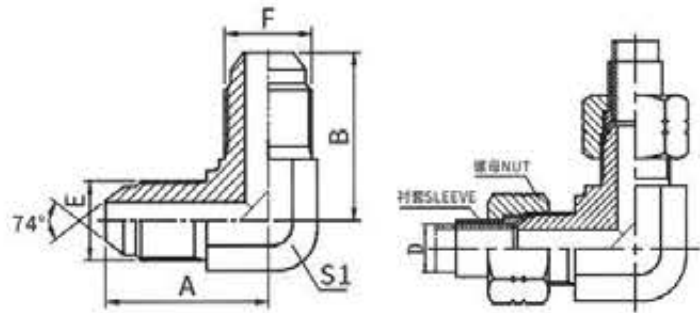

1J9

90° 弯美制JIC外螺纹74° 外锥
90° ELBOW JIC MALE 74° CONE

代号 PART NO.	螺纹 THREAD		尺寸 DIMENSIONS			
	E	F	A	B	S1	
1J9-02	5/16"X24	5/16"X24	20.5	20.5	11	
1J9-03	3/8"X24	3/8"X24	22	22	11	
1J9-04	7/16"X20	7/16"X20	24.5	24.5	11	
1J9-05	1/2"X20	1/2"X20	26.6	26.6	14	
1J9-06	9/16"X18	9/16"X18	26.9	26.9	14	
1J9-06-08	9/16"X18	9/16"X18	30	32	19	
1J9-06-10	9/16"X18	9/16"X18	32	37.8	22	
1J9-08	3/4"X16	3/4"X16	32	32	19	
1J9-08-10	3/4"X16	3/4"X16	34.8	37.8	22	
1J9-10	7/8"X14	7/8"X14	37.8	37.8	22	
1J9-10-12	7/8"X14	7/8"X14	41	44.2	27	
1J9-12	1.1/16"X12	1.1/16"X12	44.2	44.2	27	
1J9-14	1.3/16"X12	1.3/16"X12	47.5	47.5	30	
1J9-16	1.5/16"X12	1.5/16"X12	49	49	33	
1J9-20	1.5/8"X12	1.5/8"X12	55.5	55.5	41	
1J9-24	1.7/8"X12	1.7/8"X12	62.5	62.5	48	
1J9-32	2.1/2"X12	2.1/2"X12	78	78	63	

注:螺母及衬套需另行订货。管子直径D为公制时, 配用螺母及衬套分别选用NB200、NB500。管子直径为英制时, 配用螺母及衬套分别选用NB200、NB300。
Note : Nut and sleeve should be ordered separately.The nut NB200 and sleeve NB500 is suitable for metric tube,the nut NB200 and sleeve NB300 is suitable for inch tube.

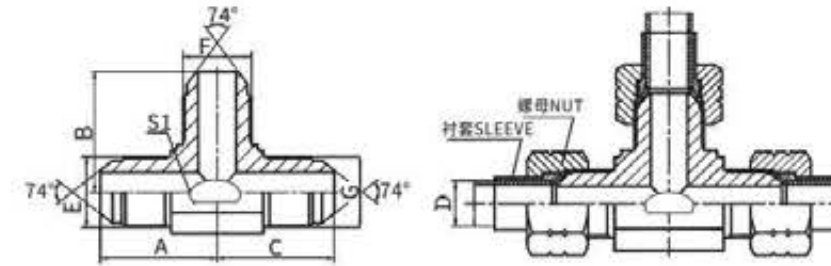

AJ

美制JIC外螺纹74° 外锥三通
JIC MALE 74° CONE TEE

代号 PART NO.	螺纹 THREAD			尺寸 DIMENSIONS			
	E	F	G	A	B	C	S1
AJ-04	7/16"X20	7/16"X20	7/16"X20	24.5	24.5	24.5	11
AJ-04-06-04	7/16"X20	9/16"X18	7/16"X20	26.6	26.9	26.6	14
AJ-05	1/2"X20	1/2"X20	1/2"X20	26	26	26	14
AJ-06-04-06	9/16"X18	7/16"X20	9/16"X18	26.9	26.6	26.9	14
AJ-06	9/16"X18	9/16"X18	9/16"X18	26.9	26.9	26.9	14
AJ-08-06-08	3/4"X16	9/16"X18	3/4"X16	32	30	32	19
AJ-10	7/8"X14	7/8"X14	7/8"X14	37.8	37.8	37.8	22
AJ-12	1.1/16"X12	1.1/16"X12	1.1/16"X12	44.2	44.2	44.2	27
AJ-16	1.5/16"X12	1.5/16"X12	1.5/16"X12	49	49	49	33
AJ-16-12-16	1.5/16"X12	1.1/16"X12	1.5/16"X12	49	48	49	33
AJ-20	1.5/8"X12	1.5/8"X12	1.5/8"X12	56.5	56.5	56.5	41
AJ-24	1.7/8"X12	1.7/8"X12	1.7/8"X12	63	63	63	48
AJ-32	2.1/2"X12	2.1/2"X12	2.1/2"X12	78	78	78	63

注:螺母及衬套需另行订货。管子直径D为公制时, 配用螺母及衬套分别选用NB200、NB500。管子直径为英制时, 配用螺母及衬套分别选用NB200、NB300。 Note : Nut and sleeve should be ordered separately.The nut NB200 and sleeve NB500 is suitable for metric tube,the nut NB200 and sleeve NB300 is suitable for inch tube.

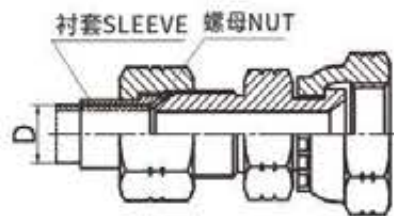
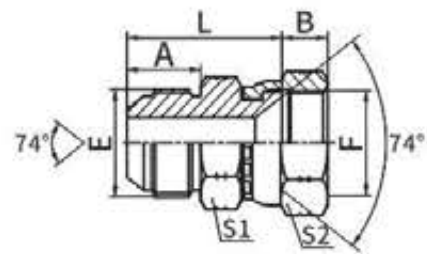

美制JIC外螺纹74° 外锥/
 JIC内螺纹74° 内锥
 JIC MALE 74° CONE/
 JIC FEMALE 74° SEAT

2J

代号 PART NO.	螺纹 THREAD		尺寸 DIMENSIONS				
	E	F	A	B	L	S1	S2
2J-04	7/16"X20	7/16"X20	14	9	28	12	15
2J-04-05	7/16"X20	1/2"X20	14	9.5	28.5	12	17
2J-04-06	7/16"X20	9/16"X18	14	10.5	28.5	14	19
2J-04-08	7/16"X20	3/4"X16	14	11	30.5	19	24
2J-05	1/2"X20	1/2"X20	14	9.5	29	14	17
2J-05-08	1/2"X20	3/4"X16	14	11	30.5	19	24
2J-06	9/16"X18	9/16"X18	14.1	10.5	29	17	19
2J-06-08	9/16"X18	3/4"X16	14.1	11	31	19	24
2J-06-10	9/16"X18	7/8"X14	14.1	13	33.5	22	27
2J-08	3/4"X16	3/4"X16	16.7	11	36	22	24
2J-08-06	3/4"X16	9/16"X18	16.7	10.5	34	22	19
2J-08-10	3/4"X16	7/8"X14	16.7	13	36.5	22	27
2J-08-12	3/4"X16	1.1/16"X12	16.7	15	39.5	27	32
2J-10	7/8"X14	7/8"X14	19.3	13	39	24	27
2J-10-08	7/8"X14	3/4"X16	19.3	11	38	24	24
2J-10-12	7/8"X14	1.1/16"X12	19.3	15	42	27	32
2J-12	1.1/16"X12	1.1/16"X12	21.9	15	44.5	30	32
2J-12-10	1.1/16"X12	7/8"X14	21.9	13	43.5	30	27
2J-12-16	1.1/16"X12	1.5/16"X12	21.9	16	45.5	36	41
2J-16	1.5/16"X12	1.5/16"X12	23.1	16	46.5	36	41
2J-16-20	1.5/16"X12	1.5/8"X12	23.1	17	53	41	50
2J-20	1.5/8"X12	1.5/8"X12	24.3	17	54.5	46	50
2J-20-24	1.5/8"X12	1.7/8"X12	24.3	20	55.5	46	55
2J-24	1.7/8"X12	1.7/8"X12	27.5	20	61	50	55
2J-24-32	1.7/8"X12	2.1/2"X12	27.5	24.5	63	65	75
2J-32	2.1/2"X12	2.1/2"X12	33.9	24.5	69.5	65	75

注:螺母及衬套需另行订货。管子直径D为公制时, 配用螺母及衬套分别选用NB200、NB500。管子直径为英制时, 配用螺母及衬套分别选用NB200、NB300。 Note : Nut and sleeve should be ordered separately.The nut NB200 and sleeve NB500 is suitable for metric tube,the nut NB200 and sleeve NB300 is suitable for inch tube.

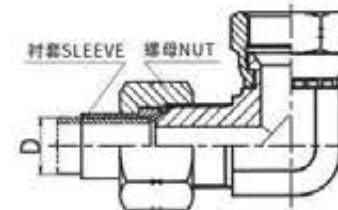
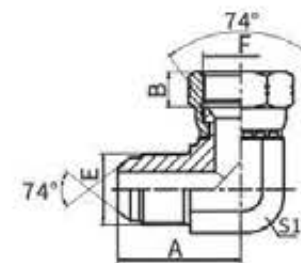

90° 弯美制JIC外螺纹74° 外锥/
 JIC内螺纹74° 内锥
 90°ELBOW JIC MALE 74° CONE/
 JIC FEMALE 74° SEAT

2J9

代号 PART NO.	螺纹 THREAD		尺寸 DIMENSIONS			
	E	F	A	B	S1	S2
2J9-02	5/16"X24	5/16"X24	21	5.6	11	12
2J9-03	3/8"X24	3/8"X24	22	5	11	14
2J9-04	7/16"X20	7/16"X20	24.5	9	11	15
2J9-05	1/2"X20	1/2"X20	26.5	9.5	14	17
2J9-06	9/16"X18	9/16"X18	26.9	10.5	14	19
2J9-08-06	3/4"X16	9/16"X18	32	10.5	19	19
2J9-08	3/4"X16	3/4"X16	32	11	19	24
2J9-08-10	3/4"X16	7/8"X14	32	13	19	27
2J9-10	7/8"X14	7/8"X14	37.8	13	22	27
2J9-10-08	7/8"X14	3/4"X16	37.8	11	22	24
2J9-10-12	7/8"X14	1.1/16"X12	39.5	15	24	32
2J9-12	1.1/16"X12	1.1/16"X12	44.2	15	27	32
2J9-12-10	1.1/16"X12	7/8"X14	44.2	13	27	27
2J9-12-16	1.1/16"X12	1.5/16"X12	46	16	30	41
2J9-14	1.3/16"X12	1.3/16"X12	47.5	15	30	36
2J9-16	1.5/16"X12	1.5/16"X12	48.8	16	33	41
2J9-16-20	1.5/16"X12	1.5/8"X12	54	17	41	50
2J9-20-16	1.5/8"X12	1.5/16"X12	55.5	16	41	41
2J9-20	1.5/8"X12	1.5/8"X12	55.5	17	41	50
2J9-20-24	1.5/8"X12	1.7/8"X12	59.5	20	48	55
2J9-24-20	1.7/8"X12	1.5/8"X12	62.5	17	48	50
2J9-24	1.7/8"X12	1.7/8"X12	62.5	20	48	55
2J9-32	2.1/2"X12	2.1/2"X12	75.5	24.5	63	75

注:螺母及衬套需另行订货。管子直径D为公制时, 配用螺母及衬套分别选用NB200、NB500。管子直径为英制时, 配用螺母及衬套分别选用NB200、NB300。 Note : Nut and sleeve should be ordered separately.The nut NB200 and sleeve NB500 is suitable for metric tube,the nut NB200 and sleeve NB300 is suitable for inch tube.

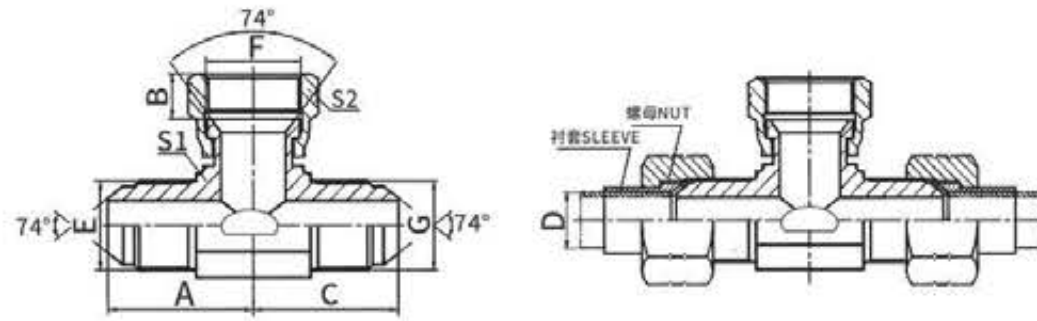

BJ

美制JIC外螺纹74° 外锥/美制JIC内螺纹74° 内锥分支三通
JIC MALE 74° CONE/JIC FEMALE BRANCH TEE

代号 PART NO.	螺纹 THREAD			尺寸 DIMENSIONS				
	E	F	G	A	B	C	S1	S2
BJ-04	7/16"X20	7/16"X20	7/16"X20	24.5	9	24.5	11	15
BJ-05	1/2"X20	1/2"X20	1/2"X20	26.5	9.5	26.5	14	17
BJ-06	9/16"X18	9/16"X18	9/16"X18	26.9	10.5	26.9	14	19
BJ-08	3/4"X16	3/4"X16	3/4"X16	32	11	32	19	24
BJ-10	7/8"X14	7/8"X14	7/8"X14	37.8	14	37.8	22	27
BJ-12	1.1/16"X12	1.1/16"X12	1.1/16"X12	44.2	15	44.2	27	32
BJ-14	1.3/16"X12	1.3/16"X12	1.3/16"X12	47.5	15	47.5	30	36
BJ-16	1.5/16"X12	1.5/16"X12	1.5/16"X12	49	16	49	33	41
BJ-20	1.5/8"X12	1.5/8"X12	1.5/8"X12	56	17	56	41	50
BJ-24	1.7/8"X12	1.7/8"X12	1.7/8"X12	62.5	20	62.5	48	55
BJ-32	2.1/2"X12	2.1/2"X12	2.1/2"X12	78	24.5	78	63	75

注:螺母及衬套需另行订货。管子直径D为公制时, 配用螺母及衬套分别选用NB200、NB500。管子直径为英制时, 配用螺母及衬套分别选用NB200、NB300。 Note: Nut and sleeve should be ordered separately. The nut NB200 and sleeve NB500 is suitable for metric tube, the nut NB200 and sleeve NB300 is suitable for inch tube.

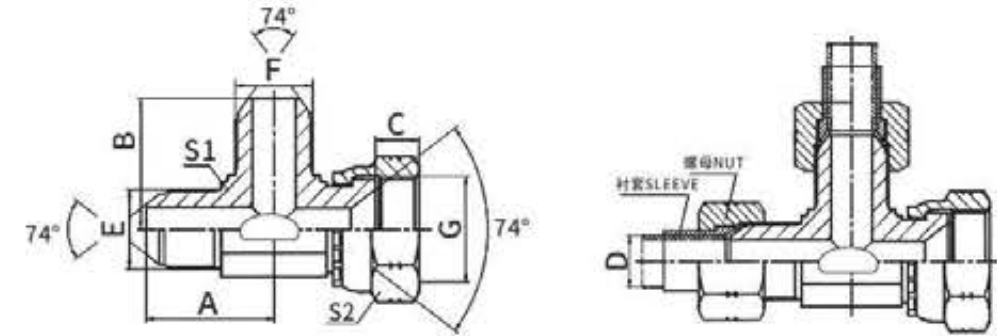

CJ

美制JIC外螺纹74° 外锥/美制JIC内螺纹74° 内锥主支三通
JIC MALE 74° CONE/JIC FEMALE 74° SEAT RUN TEE

代号 PART NO.	螺纹 THREAD			尺寸 DIMENSIONS				
	E	F	G	A	B	C	S1	S2
CJ-04	7/16"X20	7/16"X20	7/16"X20	24.5	24.5	9	11	15
CJ-05	1/2"X20	1/2"X20	1/2"X20	26.5	26.5	9.5	14	17
CJ-06	9/16"X18	9/16"X18	9/16"X18	26.9	26.9	10.5	14	19
CJ-08	3/4"X16	3/4"X16	3/4"X16	32	32	9.5	19	24
CJ-10	7/8"X14	7/8"X14	7/8"X14	37.8	37.8	13	22	27
CJ-12	1.1/16"X12	1.1/16"X12	1.1/16"X12	44.2	44.2	15	27	32
CJ-14	1.3/16"X12	1.3/16"X12	1.3/16"X12	47.5	47.5	15	30	36
CJ-16	1.5/16"X12	1.5/16"X12	1.5/16"X12	49	49	16	33	41
CJ-20	1.5/8"X12	1.5/8"X12	1.5/8"X12	56	56	17	41	50
CJ-24	1.7/8"X12	1.7/8"X12	1.7/8"X12	62.5	62.5	20	48	55
CJ-32	2.1/2"X12	2.1/2"X12	2.1/2"X12	78	78	24.5	63	75

注:螺母及衬套需另行订货。管子直径D为公制时, 配用螺母及衬套分别选用NB200、NB500。管子直径为英制时, 配用螺母及衬套分别选用NB200、NB300。 Note: Nut and sleeve should be ordered separately. The nut NB200 and sleeve NB500 is suitable for metric tube, the nut NB200 and sleeve NB300 is suitable for inch tube.

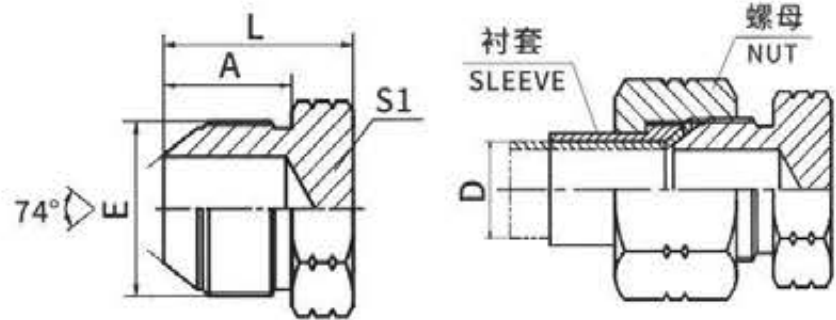

4J

美制JIC外螺纹74° 外锥堵头
JIC MALE 74° CONE PLUG

代号 PART NO.	螺纹 THREAD	尺寸 DIMENSIONS		
	E	A	L	S1
4J-04	7/16"X20	14	20	12
4J-05	1/2"X20	14	20	14
4J-06	9/16"X18	14.1	20	17
4J-08	3/4"X16	16.7	25	22
4J-10	7/8"X14	19.3	27.5	24
4J-12	1.1/16"X12	21.9	32	30
4J-14	1.3/16"X12	22.6	33.5	32
4J-16	1.5/16"X12	23.1	34	36
4J-20	1.5/8"X12	24.3	38	46
4J-24	1.7/8"X12	27.5	44.5	50
4J-32	2.1/2"X12	33.9	51	65

注:螺母及衬套需另行订货。管子直径D为公制时, 配用螺母及衬套分别选用NB200、NB500。管子直径为英制时, 配用螺母及衬套分别选用NB200、NB300。 Note: Nut and sleeve should be ordered separately. The nut NB200 and sleeve NB500 is suitable for metric tube, the nut NB200 and sleeve NB300 is suitable for inch tube.

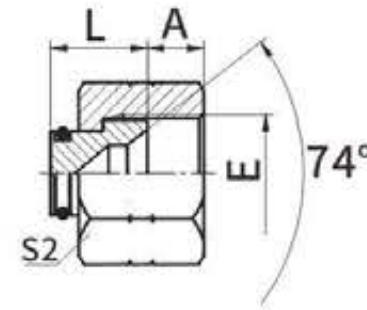

9J

美制JIC内螺纹74° 内锥堵头
JIC FEMALE 74° SEAT PLUG

代号 PART NO.	螺纹 THREAD	尺寸 DIMENSIONS		
	E	A	L	S2
9J-04	7/16"X20	9	10.5	15
9J-05	1/2"X20	9.5	11	17
9J-06	9/16"X18	10.5	11	19
9J-08	3/4"X16	11	13	24
9J-10	7/8"X14	13	13.5	27
9J-12	1.1/16"X12	15	15	32
9J-14	1.3/16"X12	15	15	36
9J-16	1.5/16"X12	16	15.5	41
9J-20	1.5/8"X12	17	18.5	50
9J-24	1.7/8"X12	20	19	55
9J-32	2.1/2"X12	23.5	20.5	75

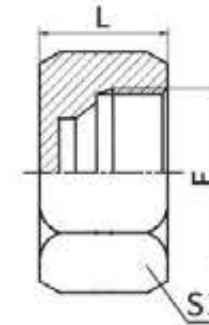

9J-CAP

JIC 74° 内螺纹堵头
JIC 74° FEMALE PLUG

代号 PART NO.	螺纹 THREAD	尺寸 DIMENSIONS	
	E	L	S1
9J-04CAP	7/16"X20	15.1	15
9J-05CAP	1/2"X20	15.5	17
9J-06CAP	9/16"X18	15.9	19
9J-08CAP	3/4"X16	19	24
9J-10CAP	7/8"X14	21.4	27
9J-12CAP	1.1/16"X12	23	32
9J-16CAP	1.5/16"X12	25.8	41
9J-20CAP	1.5/8"X12	27	50
9J-24CAP	1.7/8"X12	30.2	60
9J-32CAP	2.1/2"X12	36.5	75